

Contents

1. Cycloidal Pinwheel Reducer
 - 1.1 Preface
 - 1.2 Structure Principle
 - 1.3 Characteristics
 - 1.4 Technical Specification
 - 1.5 Contour and Installation Dimensions of Cycloidal Pinwheel Reducer
 - 1.6 Maintenance (Disassembly and Assembly)
 - 1.7 Type and Specification of Supporting Bearing Oil Seal
 2. Series of Special Cycloidal Pinwheel Reducers
 - 2.1 BJ Series of Reducers
 - 2.2 BJS Series of Reducers
 3. Instructions for Use and Lubrication
 - 3.1 Use
 - 3.2 Lubrication
 4. Racks of Chemical Retort
 - 4.1 HG5-251-79 Standard Rack
 - 4.2 DJ and LDJ Rack
 - 4.3JXLD Rack (74 Standard)
 - 4.4 DXJ Single-Fulcrum Rack
 - 4.5 SJ and LSJ Double-Fulcrum Rack
 - 4.6TJQ Rack
 - 4.7HG5-251-69 Standard Rack (Shanghai)and TJ Rack
- Quality Assurance and Ordering Instruction

I. Cycloidal Pinwheel Reducer

1.1 Preface

“GUOMAO” cycloidal pinwheel reducer, adopting the principle of planetary drive with small teeth difference as well as engagement of cycloid pin gear, is a kind of novelty transmission machinery and drive reducer widely used in the fields of textile printing, light and food industry, metallurgy mine, petrochemical industry, lifting and transport, and engineering machinery and so on.

Our company manufactures cycloidal pinwheel reducers with excellent quality, reliable performance, complete specifications and reasonable price, which are awarded the title of “Quality Products of Jiangsu and Ministry of Machine Building”.

1.2 Structure Principle

Overall transmission device of planetary cycloidal pinwheel reducer is composed of three parts, input, speed reduction and output.

Early input shaft is equipped with a double-eccentric bushing with dislocation of 180°, and eccentric bushing is equipped with two roller bearings to form H structure. Center hole of two cycloidal wheels is the roller path of tumbler bearing on eccentric bushing, and a group of circular pinwheels are engaged in cycloidal wheel and pin wheel, so that inner gearing reducer structure with small teeth difference takes shape, (pin gear is equipped with pin gear set in the reducer with small speed ratio to reduce friction)

When input shaft moves a circle together with eccentric bushing, due to the characteristics of flank curve of cycloidal wheel and the restraint of gear pin of pin wheel, cycloidal wheel starts plane motion with revolution and autorotation. When input shaft moves forward a circle, so does eccentric bushing. And cycloidal wheels get through a teeth difference in the opposite direction, so that speed is reduced. By means of W output structure, low-speed autorotation motion of cycloidal wheel is transferred to output shaft through pin roll, so lower output speed is achieved

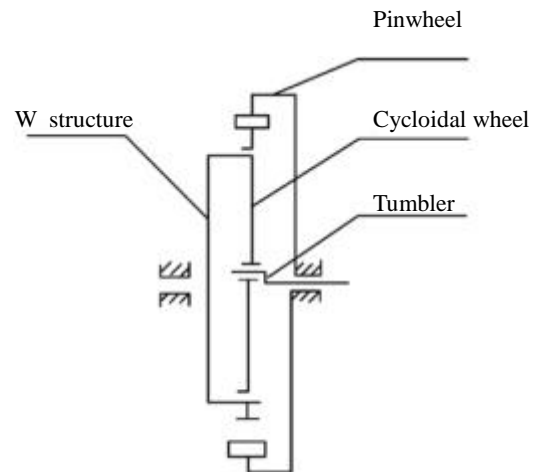

1.3 Characteristics

1.3.1 High reduction ratio and efficiency

Single-stage transmission can produce the reduction ration of 1:87 and over 90% efficiency. Multi-stage transmission will offer higher reduction ratio.

1.3.2 Compact structure and small volume

Due to the adoption of planetary transmission principle, input shaft and output shaft are at the same axis, so it has compact structure and small volume.

1.3.3 Stable operation and low noise

Cycloidal gear pins have more engagement, bigger overlap coefficient and mechanism of stable machine parts, so

1.3.4 Reliable operation and long service life

Major parts are manufactured with bearing steel, so they have excellent mechanical performance. The adoption of rolling friction makes them durable in use.

1.3.5 Powerful overload capacity, strong resistance to impact, small moment of inertia, and applicable to occasions with frequent starts and positive and negative rotating.

GUOMAO REDUCER

1. Model No. Chart 1

First-stage	Second-stage	Third-stage
09	10	2009
0	20	310
1	31	420
2	41	531
3	42	631
4	52	742
5	53	852
6	63	953
7	74	
8	84	
9	85	
	95	

2. Transmission ratio Chart 2

First-stage	Second-stage		Third-stage
7	99(9×11)	1505(35×43)	Shown as Chart 7
9	121(11×11)	1849(43×43)	
11	187(11×17)	2065(35×59)	
17	289(17×17)	2537(43×59)	
23	391(17×23)	3481(59×59)	
29	493(17×29)	4189(59×71)	
35	595(17×35)	5133(59×87)	
43	731(17×43)	7569(87×87)	
59	841(29×29)		
71	1003(17×59)		
87	1225(35×35)		

Note: In line with structural style, it is grouped into horizontal type and vertical type; in line with the connecting way of driver, it is grouped into double-shaft type, motor connecting type and motor direct-coupled type

Note: Second-stage and third-stage type of machines can willfully combine the transmission ratio of first-stage type of machines. You'd better contact with our technical department if you need other transmission ratio.

3. Table of comparison for models of cycloidal pinwheel reducers

Standard of reducer	First-stage											
	JB/T2982-94A	X1	X2	X3	X4	X5	X6	X7	X8	X9	X10	X11
JB/T2982-94B	B09	B0	B1	B2	B3	B4		B5	B6	B7	B8	B9
JB2982-81		B12	B15	B18	B22	B27		B33	B39	B45	B55	B65
Standard of reducer	Second-stage											
	JB/T2982-94A	X32	X42	X53	X63	X64	X74	X84	X85	X95	X106	X118
JB/T2982-94B	B10	B20	B31	B41	B42		B52	B53	B63	B74	B85	B95
JB2982-81		B1812	B2215	B2715	B2718		B3318	B3322	B3922	B4527	B5533	B6533

Note: Different standard models basically have the same performance index but a little difference in contour, installation and connecting dimensions, and users should select JB/T2982-94 A or B standard to the greatest extent.

GUOMAO REDUCER

4. Model expressions

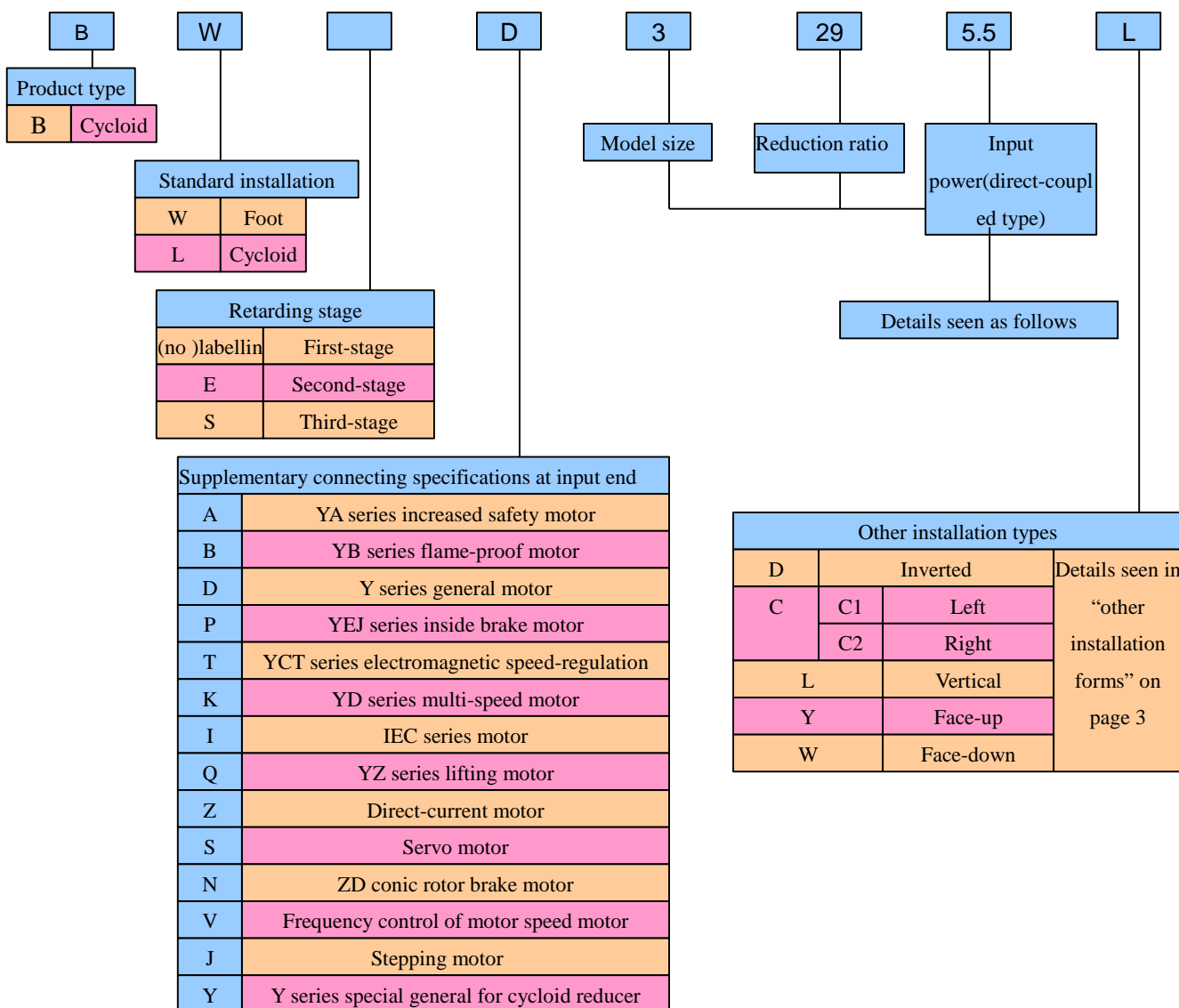

Input power

Input power – only applicable to direct-coupled motor (kw)																					
Power 4	0.18	0.25	0.37	0.55	0.75	1.1	1.5	2.2	3.0	4.0	5.5	7.5	11	15							
Power 6															18.5	22	30	37	45	55	75

5. Demonstration of models

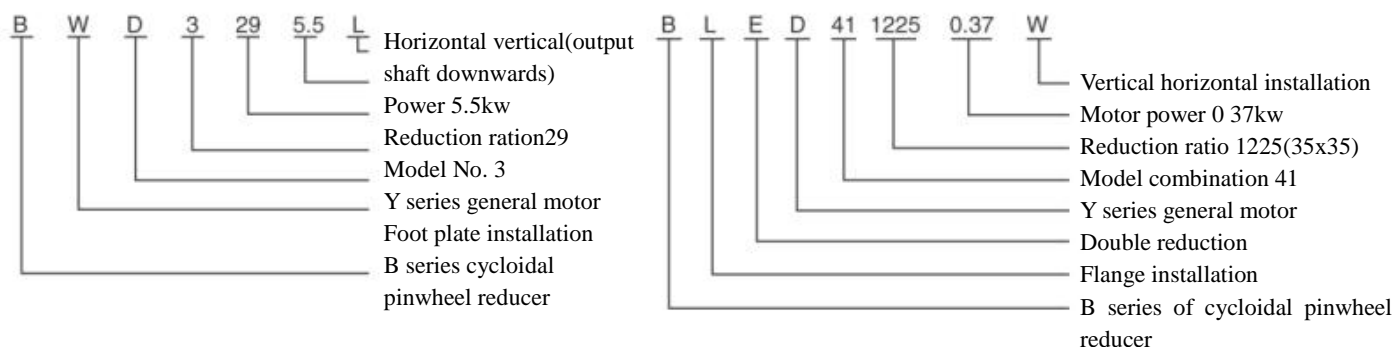









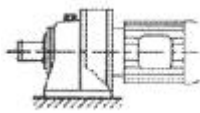
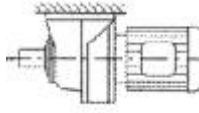
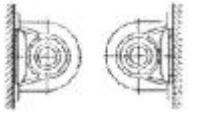

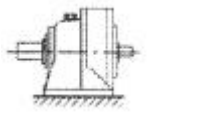
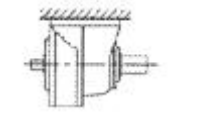
Note: In principle, combination of all levels of transmission ratio takes the first-stage (high speed end) transmission ratio as the smaller one. In the second-stage and third-stage reducer, the transmission ratio in the

GUOMAO REDUCER

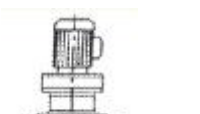
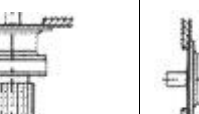
first-stage or second-stage (low speed end) as the bigger transmission ratio

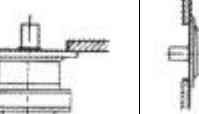
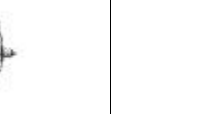
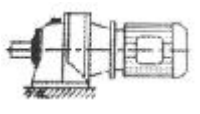
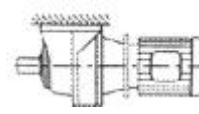
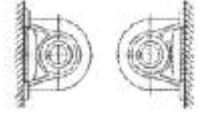
6. Installation types

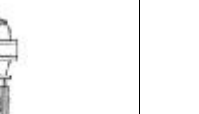
Standard installation types	Other installation types				
	Inverted	Sided	Vertical	Face-up	Horizontal
BWY 	D 	C1 C2 	L 	Y 	
Horizontal direct-coupled	Horizontal direct-coupled inverted	Horizontal direct-coupled sided	Horizontal direct-coupled vertical	Horizontal direct-coupled face-up	
BW 	D 	C1 C2 	L 	Y 	
Horizontal double-shaft	Horizontal double-shaft inverted	Horizontal double-shaft sided	Horizontal double-shaft vertical	Horizontal double-shaft face-up	
BLY type 				Y 	W 
Vertical direct-coupled				Vertical direct-coupled face-up0	Vertical direct-coupled face-down
BL type 				Y 	W 
Vertical double-shaft				Vertical double-shaft face-up	Vertical double-shaft face-down
BWD type 	D 	C1 C2 	L 	Y 	
Horizontal general motor model	Horizontal general motor model Inverted installation	Horizontal general motor model Inverted installation	Horizontal general motor model Vertical Installation	Horizontal general motor model Face-up Installation	

GUOMAO REDUCER

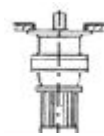
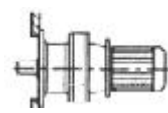
BLD type 				Y 	W 
Vertical motor connecting type(with motor)				Vertical motor connecting type(with motor)face-up installation	Vertical motor connecting type(with motor)face-down installation

7. Bearing capacity

Allowable power and torque of single transmission reducer (bearing coefficient K=1.00)

Chart 5

Model No.	Allowable input power Allowable output torque	Transmission ratio I										Scope of allowable power	
		9	10	17	23	29	35	43	59	71	87	Pmax	Pmin
Input speed n1		1500 (r/min)										NO. of motor poles 4P	
B09/×1	P(kW) T(N.m)	0.55 0.30	0.37 26	0.37 38	0.25 37	0.25 43	0.25 52	0.18 50				0.55	0.18
B0/×2	P(kW) T(N.m)	1.1 58	1.1 70	0.75 74	0.75 101	0.55 93	0.55 112	0.37 93	0.25 86			1.1	0.18
B1/×3	P(kW) T(N.m)	2.2 117	2.2 143	2.2 220	1.5 203	1.1 188	1.1 227	0.75 190	0.55 191	0.55 230		2.2	0.25
B2/×4	P(kW) T(N.m)	4 210	4 260	4 400	3 400	2.2 373	1.5 307	1.5 377	1.1 380	0.75 315	0.75 380	4	0.55
B3/×5	P(kW) T(N.m)	11 580	7.5 485	7.5 750	5.5 745	5.5 935	4 820	4 1010	2.2 765	2.2 915	1.5 765	11	0.55
B4/×6/×7	P(kW) T(N.m)	11 580	11 713	11 1100	11 1485	7.5 1280	7.5 1540	5.5 1390	4 1390	4 1670	3 1530	11	2.2
B5/×8	P(kW) T(N.m)		18.5 1191	18.5 1842	18.5 2492	15 2547	15 3075	11 2770	7.5 2591	7.5 3119	5.5 2802	18.5	2.2
B6/×9	P(kW) T(N.m)								15 5183	11 4574	11 5605	15	5.5
B7/10	P(kW) T(N.m)										15 7643	15	11
Output speed n2 (r/min)		167	136	88	65	52	43	35	25	21	17	Input speed in the opposite direction	
Input speed n1		1000 (r/min)										NO. of motor poles 6P	
B09/×1	P(kW) T(N.m)	0.37 30	0.25 25	0.25 37	0.18 37	0.18 45	0.18 55	0.12 45				0.37	0.12
B0/×2	P(kW) T(N.m)	0.75 59	0.75 75	0.55 80	0.55 110	0.37 94	0.37 112	0.25 93	0.18 93			0.75	0.12
B1/×3	P(kW) T(N.m)	1.5 118	1.5 145	1.5 224	1.1 220	1.1 275	0.75 230	0.55 205	0.37 190	0.37 225		1.5	0.18



GUOMAO REDUCER

B2/×4	P(kW) T(N.m)	3 235	3 290	3 448	2.2 445	1.5 385	1.1 340	1.1 415	0.75 388	0.55 343	0.55 420	3	0.37
B3/×5	P(kW) T(N.m)	7.5 593	5.5 531	5.5 820	4 810	4 1020	3 925	3 1135	1.5 775	1.5 935	1.1 840	7.5	0.37
B4/×6/×7	P(kW) T(N.m)	7.5 593	7.5 735	7.5 1125	7.5 1520	5.5 1405	5.5 1700	4 1515	3 1560	3 1870	2.2 1680	7.5	1.5
B5/×8	P(kW) T(N.m)		11 1063	11 1642	11 2222	11 2802	11 3382	7.5 2833	5.5 2851	5.5 3430	4 3057	11	1.5
B6/×9	P(kW) T(N.m)		22 2126	22 3285	22 4445	18.5 4713	18.5 5688	15 5666	11 5702	7.5 4678	7.5 5732	22	3
B7/×10	P(kW) T(N.m)		37 3576	37 5526	37 7476	37 9427	30 9225	22 8311	18.5 9589	18.5 11540	15 11465	37	11
B8/×11	P(kW) T(N.m)		55 5315	55 8214	55 11114	55 14013	45 13838	37 13978	30 15551	22 13723	22 16816	55	18.5
B9/×12	P(kW) T(N.m)				75 15155	75 19109	55 16913	55 20778	45 23326	37 23080	30 22931	75	30
Output speed n2 (r/min)		111	91	59	43	34	29	23	17	14	11	NO. of motor poles 6P	

Note: 1. In the formula of $T = 9550 \cdot P \cdot i \cdot \eta \cdot Q \cdot n_1$ (N.m), $P: T \cdot n_1 / (9550 \cdot i \cdot \eta \cdot Q)$ (kW), first-stage transmission efficient η is defined as 0.925.

2. When motor direct-coupled reducer is selected for use, the actual allocated motor power should conform to the scope of allowable power. If the allocated motor power is more than allowable motor power, the reducer is only allowed to use in line with regulated allowable torque.



GUOMAO REDUCER

Allowable power and torque of double-staged transmission reducer(bearing coefficient K=1.00) Chart 6

Model No.	Allowable input power Allowable output torque	Transmission ratio i										Scope of allowable power	
		99	121	187	289	391	493	595	731	841	1003	Pmax	Pmin
		11×9	11×11	17×11	17×17	23×17	29×17	35×17	43×17	29×29	59×17		
Input speed n1		1500 (r/min)										NO. of motor poles 4P	
B10/×32	P(kW) T(N.m)	0.3 175	0.27 175	0.18 175	0.12 175	0.08 175	0.07 175	0.06 175	0.05 175	0.04 175	0.03 175	0.37	0.18
B20/×42	P(kW) T(N.m)	1.12 600	0.92 600	0.59 600	0.38 600	0.28 600	0.22 600	0.19 600	0.15 600	0.13 600	0.11 600	1.1	0.18
B31/×53	P(kW) T(N.m)	2.2 1250	1.91 1250	1.24 1250	1.08 1250	0.59 1250	0.47 1250	0.39 1250	0.32 1250	0.27 1250	0.23 1250	2.2	0.25
B41/×63	P(kW) T(N.m)	2.2 1179	2.2 1441	2.2 2226	1.6 2500	1.18 2500	0.94 2500	0.78 2500	0.63 2500	0.55 2500	0.46 2500	2.2	0.25
B42/×64	P(kW) T(N.m)	4 2143	3.82 2500	2.47 2500	1.6 2500	1.18 2500	0.94 2500	0.78 2500	0.63 2500	0.55 2500	0.46 2500	4	0.55
B52/×84	P(kW) T(N.m)	4.1 2143	4 2619	4 4048	3.2 5000	2.36 5000	1.87 5000	1.55 5000	1.26 5000	1.1 5000	0.92 5000	4	0.55
B53/×85	P(kW) T(N.m)	9.3 5000	7.5 4911	4.94 5000	3.2 5000	2.36 5000	1.87 5000	1.55 5000	1.26 5000	1.1 5000	0.92 5000	7.5	0.55
B63/×95	P(kW) T(N.m)	11 5893	7.5 4916	7.5 7590	5.64 8820	4.19 8820	3.32 8820	2.75 8820	2.24 8820	1.95 8820	1.62 8820	7.5	0.55
B74/106	P(kW) T(N.m)			11 11132	7.67 12000	5.67 12000	4.5 12000	3.73 12000	3.03 12000	2.64 12000	2.21 12000	11	2.2
B84/×117	P(kW) T(N.m)			11 11132	10.27 16000	7.59 16000	6 16000	5 16000	4 16000	3.53 16000	3 16000	11	2.2
B85/×118	P(kW) T(N.m)			15 16430	13.8 21560	10.2 21560	8.1 21560	6.7 21560	5.47 21560	4.75 21560	3.9 21560	15	2.2
B95/128	P(kW) T(N.m)					13.9 29400	11 29400	9.15 29400	7.46 29400	6.48 29400	5.43 29400	15	2.2
Output speed n2 (r/min)		14.5	11.9	8.02	5.19	3.84	3.04	2.52	2.05	1.78	1.5	Input speed in the same direction	
Model No.	Allowable input power Allowable output torque	Transmission ratio i										Scope of allowable power	
		1225	1505	1849	2065	2537	3481	4189	5133	7569		Pmax	Pmin
		35×35	43×35	43×43	59×35	59×43	59×59	71×59	87×59	87×87			
Input speed n1		1500 (r/min)										NO. of motor poles 6P	
B10/×32	P(kW) T(N.m)	0.02 150	0.02 150	0.01 150	0.01 150	0.01 150	0.01 150	0.01 150				0.18	0.18
B20/×42	P(kW) T(N.m)	0.09 600	0.07 600	0.06 600	0.05 600	0.04 600	0.03 600	0.03 600	0.02 600			0.18	0.18
B31/×53	P(kW) T(N.m)	0.19 1250	0.15 1250	0.12 1250	0.11 1250	0.09 1250	0.07 1250	0.06 1250	0.04 1250			0.55	0.55
B41/×63	P(kW) T(N.m)	0.38 2500	0.31 2500	0.25 2500	0.22 2500	0.18 2500	0.13 2500	0.11 2500	0.09 2500			0.55	0.55
B52/×84	P(kW) T(N.m)	0.75 5000	0.61 5000	0.5 5000	0.45 5000	0.36 5000	0.27 5000	0.22 5000	0.18 5000	0.12 5000		1.1	0.55
B63/×95	P(kW) T(N.m)	1.33 8820	1.08 8820	0.88 8820	0.79 8820	0.64 8820	0.47 8820	0.39 8820	0.31 8820	0.21 8820		1.1	1.1
B74/×106	P(kW) T(N.m)	1.81 12000	1.47 12000	1.2 12000	1.07 12000	0.87 12000	0.64 12000	0.53 12000	0.43 12000	0.29 12000		2.2	2.2
B84/×117	P(kW)	2.42	1.97	1.6	1.43	1.17	0.85	0.7	0.57	0.39		3	2.2



GUOMAO REDUCER

	T(N.m)	16000	16000	16000	16000	16000	16000	16000	16000	16000			
B85×118	P(kW)	3.26	2.67	2.16	1.95	1.58	1.15	0.96	0.77	0.53		4	4
	T(N.m)	21560	21560	21560	21560	21560	21560	21560	21560	21560			
B95×128	P(kW)	4.45	3.62	2.95	2.64	2.15	1.56	1.3	1.06	0.71		5.5	4
	T(N.m)	29400	29400	29400	29400	29400	29400	29400	29400	29400			
Output speed n2 (r/min)		1.22	1	0.81	0.73	0.59	0.43	0.36	0.29	0.2		Input speed in the opposite direction	

Note: 1. In the formula of $T=9550 \cdot P \cdot i \cdot \eta \cdot \eta_1$ (N.m): $P=T \cdot n_1 / (9550 \cdot i \cdot \eta \cdot \eta_1)$ (kW), first-stage transmission efficient η_1 is defined as 0.925.

2. When motor direct-coupled reducer is selected for use, the actual allocated motor power should conform to the scope of allowable power. If the allocated motor power is more than allowable motor power, the reducer is only allowed to use in line with regulated allowable torque.

3. Allowable radial force of output shaft refers to first-stage transmission

Third-stage transmission

Chart 7

Model No.	B2009	B310	B420	B531	B631	B742	B852	B953
Allowable radial force of output shaft(N)	10000	12000	15000	40000	60000	70000	100000	180000
Allowable output torque(N.m)	600	1250	2500	5000	8820	12000	21560	29400
Transmission ratio								
11×17×43=8041	9×43×43=16641	23×23×59=31211		11×59×87=56463		23×59×87=118059		
17×17×29=8381	17×23×43=16813	9×59×59=31329		23×35×71=57155		29×59×71=121401		
11×11×71=8591	17×17×59=17051	17×43×43=31433		23×29×87=58029		35×59×59=121835		
9×11×87=8613	17×29×35=17255	11×35×87=33495		23×43×59=58351		17×87×87=128673		
11×23×35=8855	11×23×71=17963	11×43×71=33583		17×59×59=59177		35×43×87=130935		
9×23×43=8901	9×23×87=18009	9×43×87=33669		29×29×71=59711		43×43×71=131279		
17×23×23=8993	23×23×35=18515	17×23×87=34017		29×35×59=59885		23×71×87=142071		
9×17×59=9027	9×29×71=18531	23×35×43=34615		17×43×87=63597		29×71×71=146189		
9×29×35=9135	9×35×59=18585	17×29×71=35003		35×43×43=64715		35×59×71=146615		
11×29×29=9251	11×29×59=18821	17×35×59=35105		11×71×87=67947		29×59×87=148857		
17×17×35=10115	23×29×29=19343	29×35×35=35525		9×87×87=68121		43×59×59=149683		
11×11×87=10527	11×43×43=20339	29×29×43=36163		23×35×87=70035		43×43×87=160863		
9×17×71=10863	17×17×71=20519	23×23×71=37559		23×43×71=70735		23×87×87=174087		
11×23×43=10879	17×35×35=20825	9×59×71=37701		17×59×71=71213		35×71×71=176435		
9×35×35=11025	17×29×43=21199	11×59×59=38291		29×35×71=72065		29×71×87=179133		
11×17×59=11033	11×23×87=22011	23×29×59=39353		35×35×59=72275		35×59×87=179655		
9×35×35=11027	9×35×71=22365	11×43×87=41151		29×29×87=73167		43×59×71=180127		
11×29×35=11165	11×29×71=22649	17×35×71=42245		29×43×59=73573		59×59×59=205379		
9×29×43=11223	9×29×87=22707	23×43×43=42527		43×43×43=79507		35×71×87=216195		
17×23×29=11339	11×35×59=22715	35×35×35=42875		23×59×59=80063		43×71×71=216763		
23×23×23=12167	23×23×43=22747	17×29×87=42891		11×87×87=83259		29×87×87=219501		
9×23×59=12213	9×43×59=22833	17×43×59=43129		17×71×71=85697		43×59×87=220719		
17×17×43=12427	17×23×59=23069	29×35×43=43645		23×43×87=86043		59×59×71=247151		
11×17×71=13277	23×29×35=23345	9×71×71=45369		35×35×71=86975		35×87×87=264915		
9×17×87=13311	29×29×29=24389	23×23×87=46023		17×59×87=87261		43×71×87=265611		
11×35×35=13475	17×17×87=25143	11×59×71=46079		29×35×87=88305		59×71×71=297419		
9×35×43=13545	17×35×43=25585	9×59×87=46179		29×43×71=88537		59×59×87=302847		



GUOMAO REDUCER

17×23×35=13685	11×35×71=27335	23×29×71=47357	35×43×59=88795	43×87×87=325467
11×29×43=13717	9×35×87=27405	23×35×59=47495	23×59×71=96347	71×71×71=357911
17×29×29=14297	9×43×71=27477	29×29×59=49619	9×59×59=100949	259×71×87=364443
9×23×71=14697	11×29×87=27753	17×35×87=51765	17×71×87=105009	71×71×87=438567
11×23×59=14927	17×23×71=27761	17×43×71=51901	35×35×87=106575	59×87×87=446571
23×23×29=15341	11×43×59=27907	35×35×43=52675	35×43×71=106855	71×87×87=537399
9×29×59=15399	23×35×35=28175	29×43×43=53621	29×43×87=108489	87×87×87=658503
11×17×87=16269	17×29×59=29087	11×71×71=55451	43×43×59=109091	
11×35×43=16555	29×29×35=29435	9×71×87=55593	23×71×71=115943	

Note: Third-stage type of machines can willfully combine the transmission ratio of first-stage type of machines. Please contact with corporate technical department if you need other transmission ratio.

Table of radial force of first-stage transmission output shaft

Chart 8

Model No.	Transmission ratio	11	17	23	29	35	43	59	71	87
B09	Allowable radial force of output shaft(N)	700	800	800	1010	1010	1010			
B0		1660	1900	2040	2390	2390	2500	2500		
B1		2230	2550	2750	3210	3210	3620	4050	4360	
B2		3460	3960	4260	4980	4980	5630	6250	6770	6770
B3		4940	5660	6100	7130	7130	8050	8990	9690	9690
B4		6680	7650	8240	9630	9630	10870	12140	13080	13080
B5		12850	17460	18520	20900	22000	22000	23400	25200	27600
B6		27200	29100	33500	37300	39100	41300	41300	44100	44100
B7		34100	39800	39800	46800	49100	51800	55400	60400	60400
B8			50400	53700	59300	62100	65600	70100	76400	76400
B9			101000	101000	101000	125000	132000	132000	132000	

8. Instruction for model selection

1. Select types of installation

- a) Select standard types of installation ;
- b) Select all kinds of special installation types and confirm supplementary code.

2. Does motor direct-coupled reducer need special power force ?

Select all kinds of power forces and confirm supplementary code.

3. Confirm bearing coefficient $k = ?$

- a) Check Chart 9 to confirm load category (load properties) in line with usage of supporting equipment ;
- b) Check Chart 10 to confirm load coefficient k in line with load category and work condition (use --- hours per day)

4. Confirm input speed of reducer $n_1 = ?$

- a) The maximum input speed of reducer is 1500r/min
- b) Standard configuration of direct-coupled motor is 4-pole motor with synchronous speed 1500r/min , or 6-pole motor with synchronous speed 1000r/min ;
- c) When adjustable motor or variable speed drive is adopted, constant power should be the lowest speed and constant torque should be the maximum speed.

5. Confirm transmission ratio of reducer $i = ?$

- a) Confirm output speed of reducer $n_2 = ?$ (r/min) in line with supporting equipment
- b) Calculate transmission ratio $i = n_1/n_2$ and check Chart 5 or Chart 6 for sure.

6. Confirm input power of reducer $P_1 = ?$ or need output torque $T_2 = ?$

Method one: $P_1 = T_2 n_1 / (9550 i) Q$ (kW) ;

Method two: $T_2 = 9550 P_1 i Q / n_1$ (N.m)

GUOMAO REDUCER

First-stage transmission efficiency η_1 is 0.925 , and second-stage transmission efficiency η_2 is 0.85.

7. Calculate the model with equivalent input power $P_d = ?$ or equivalent output torque $T_d = ?$

method one: Calculate the model with equivalent input power $P_d = KP_1$ (kW) in line with load coefficient K

method two: Calculate the model with equivalent output torque $T_d = KT_2$ (N.m) in line with load coefficient K

8. Select product series and seat No. = ? of reducer

On the basis of above comprehensive parameters, product series and seat No. can be selected by checking Chart 5 and Chart 6 ;

Method one: equivalent input power should be no more than allowable input power listed in the Chart, namely $P_d \leq P$;

Method two: Equivalent output torque should be no more than allowable output torque listed in the Chart, namely $T_d \leq T$.

Example 1:

Known number: Belt conveyer with uneven feeding works 12 hours a day, with input power $P_1 = 0.75$ kW and output speed $n_2 = 35$ r/min, and motor direct-coupled reducer is installed in the foot-typed horizontal manner with 4-pole motor.

Model selection:

1. No. of installation type is WD;
2. Load classification of look-up table 9 is M and load coefficient of look-up table 10 is $K = 1.35$;
3. Input speed $n_1 = 1500$ r/min ;
4. Transmission ratio $i = 1500/35 = 42.86$ is selected as 43;
5. Power of matching motor is 0.75 kW;
6. Equivalent input power $P_d = 1.35 \times 0.75 = 1.01$ kW. , seat No. is 2 in look-up table 5 , allowable input power $P = 1.5$ kW $> P_d = 1.01$ kW, reducer is allowed to operate with full capacity of allocating power, and model selection is permitted.

Reducer model No.: BWD2-43-0.75

Example 2:

Known number:

Daily cosmetics stirrer, with mixed feeding and full-time work, needs output torque $T_2 = 50$ N.m, output speed $n_2 = 60$ r/min and input speed $n_1 = 1000$ r/min; it is installed in flange-typed vertical manner, and double-shaft reducer is equipped with self-made motor.

Model selection:

1. No. of installation type is L;
2. Load classification of look-up table 9 is M and load coefficient of look-up table 10 is $K = 1.35$;
3. Input speed $n_1 = 1000$ r/min ;
4. Transmission ratio $i = 1000/60 = 16.67$ is selected as 17;
5. Motor is not equipped;
6. Equivalent input torque $T_d = 1.35 \times 50 = 67.5$ N.m, seat No. is 0 in look-up table 5, allowable output torque $T = 74$ N.m $> T_d = 67.5$ N.m, reducer is allowed to operate with output torque, and model selection is permitted.

Reducer model No.: BL0-17

GUOMAO REDUCER

Load classification

Table 9

Usage		Load classification		Usage		Load classification	
stirrer	pure liquid	U	petroleum industry	paraffin press	M		
	liquid and solid	M		crystallization machine\condenser\rotary furnace	M		
	liquid(variable density)	M	*plastic machinery	extruder(granule\bar stock\tubing)	U		
air blower	centrifugal \ vane	U	*rubber machinery	blow molding machine	M		
	impeller	M		rubber crusher\mixing mill	H		
compressor	centrifugal	U	textile machinery	desizing machine\ calender	M		
	impeller \ multi-cylinder reciprocating	M		loom\carding machine\mangle	M		
	single cylinder reciprocating	H		spinning machine \rinsing machine \dyeing machine	M		
transport machinery	uniform feeding	U	food machinery	bottler\packer	U		
	uneven feeding	M		cane grinder\cut-off machine*presser	M		
	reciprocating and vibrating	H		blender\ meat grinder	M		
* Hoist(Winch)	heavy	H		puree bucket	M		
	medium	M		scouring mill	U		
*stone machinery	ball grinder\ cylindrical grinder	H		beet washing machine\cut-off machine	M		
	grinder\crusher \converter	H	other machinery	Successive one-way revolving and stable load	U		
general ceramics machinery	M	medium impact load		M			
medical machinery	U	large impact load		H			

Note:1.Load classification: U stands for stable load , M for medium impact load and H for large impact load ;
 2.*means bad working condition. Working condition of 24 hours per day should be selected when load coefficient K is confirmed in the following Chart.

Load coefficient K

Chart 10

Working condition (use ~ hours / day)	Load classification(load properties)		
	U	M	H
Interrupted ;Ü ;Ü0	Stable	Medium impact	Large impact
	0.80	1.00	1.35
Successive > 10-24	1.00	1.20	1.50
	1.20	1.35	1.60

Note:1. Our reducers are designed for the working requirement that reducer can work for 10 hours per day under stable load with load coefficient k=1.00 ;
 2. Due to different working conditions of supporting equipments, amendment of load coefficient should refer to this Chart when models are selected.

GUOMAO REDUCER

1.4 Contour and Installation Dimensions of Cycloidal Pinwheel Reducer

Model BW. BWD. XW. XWD(Single reduction) Contour And Installation Dimensions

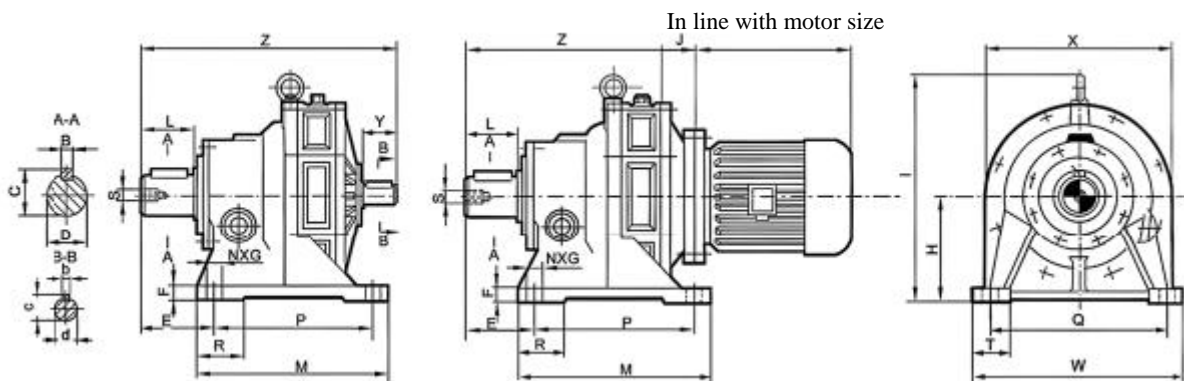

size	Contour Dimension						Installation Dimensions											Size of Shaft End							Weight(kg)			
	M	W	Z		I	X	J	H	E	F	P	Q	R	S	T	N	G	B	C	D	L	b	c	d	y	BW	BWD About	
BW.BWD09-9																												
B09	100	144	192	142	155	140		80	47	12	76	120		M5	35	4	11	6	25	22	30	5	17	15	22	8.5		
B0	120	185	214	165	190	168		100	93	15	90	150		M8	35	4	11	8	33	30	35	5	17	15	22	15		
B1	160	280	263	194	250	200		120	125	15	110	240		M10	55	4	13	10	38	35	56	6	20.5	18	35	22		
B2	200	320	320	246	296	240		140	144	20	150	280	65	M10	60	4	13	14	48.5	45	71	6	24.5	22	40	40		
B3	250	390	390	294	355	300		160	159	25	200	340	100	M12	75	4	17	16	59	55	80	8	33	30	55	73		
B4	380	400	479	370	430	340		200	155	25	320	340	150	M12	80	4	22	20	74.5	70	102	10	38	35	62	120		
B5	440	470	564	438	513	400		240	159	32	380	420		M16	80	4	22	25	95	90	120	14	48.5	45	70	185		
B6	520	560	668	528	605	500		280	199	35	440	500		M20	90	4	26	28	106	100	139	14	53.5	50	80	380		
B7	600	690	775	578	706	575		325	230	40	500	630		M24	105	6	26	28	116	110	150	16	59	55	90	580		
B8	810	880	1061	814	880	700		420	324	50	660	800		M30	160	6	32	32	137	130	202	20	74.5	70	120	1200		
B9	1040	1160	1462	1151	1160	1000		540	485	60	840	1050		M42	200	6	45	45	190	180	330	25	95	90	150	2500		
XW.XWD1-12																												
X1	120	180	197	147	175	140		100	60	12	90	150		M35	35	4	12	8	28	25	35	5	17	15	22	8.5		
X2	120	210	216	164	190	168		100	101	15	90	180		M45	45	4	12	8	28	25	34	5	17	15	22	15		
X3	150	290	263	194	270	200		140	151	20	100	250		M55	55	4	16	10	38	35	56	6	20.5	18	35	30		
X4	195	330	320	246	316	240		150	169	22	145	290		M65	65	4	16	14	48.5	45	74	6	24.5	22	40	43		
X5	260	410	401	305	356	300		160	206	25	150	370		M75	75	4	16	16	59	55	91	8	33	30	55	85		
X6	335	430	466	359	425	340		200	125	30	275	380		M12	75	4	22	18	69	65	89	10	38	35	62	125		
X7	380	470	484	377	484	340		220	145	30	320	420		M12	95	4	22	22	85	80	109	12	43	40	65	190		
X8	440	530	564	438	514	400		250	155	35	380	480		M16	120	4	22	25	95	90	120	14	48.5	45	70	240		
X9	560	620	691	528	514	500		290	186	40	480	560		M20	120	4	26	28	106	100	141	14	53.5	50	80	390		
X10	600	690	775	578	706	575		325	230	40	500	630		M24	105	6	26	28	116	110	150	16	59	55	90	580		
X11	810	880	1061	814	880	700		420	324	50	660	800		M30	160	6	32	32	137	130	202	20	74.5	70	120	1200		
X12	1040	1160	1462	1151	1160	1000		540	485	60	840	1050		M42	200	6	45	45	190	180	330	25	95	90	150	2500		

GUOMAO REDUCER

Model BL, BLD, XL and XLD (Single reduction) Contour and Installation Dimensions

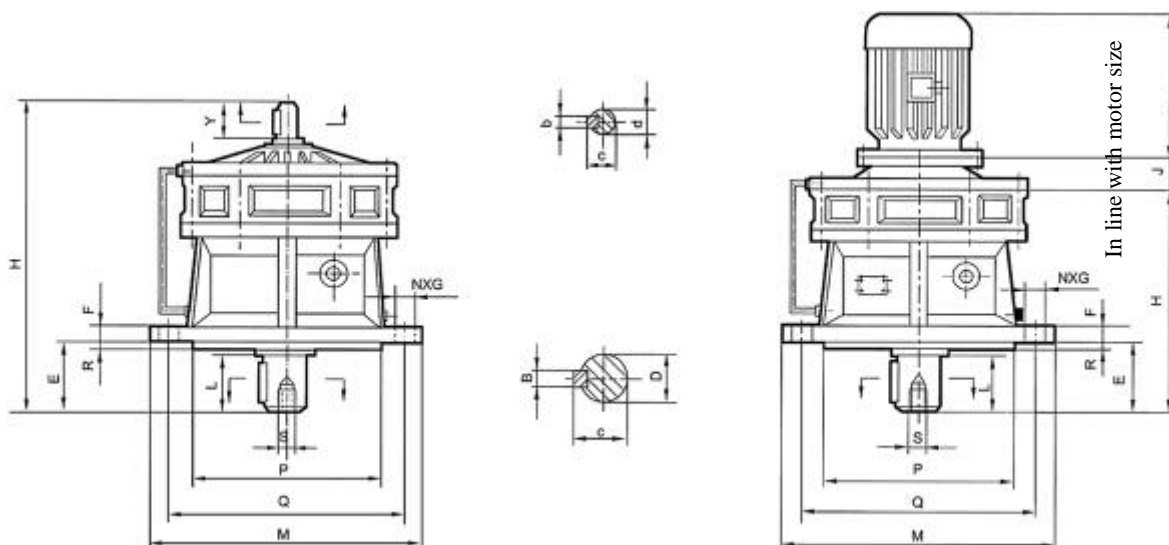

Size	Contour Dimension				Installation Dimensions								Size of Shaft End								Weight(kg)	
	H		M	J	E	F	G	N	P	Q	R	S	B	C	D	L	b	c	d	y	BL	BLD About
BL	BLD																					
BL.BLD09-9																						
B09	192	142	160	Chart 11	35	10	11	4	110	134	3	M5	6	24.5	22	30	5	17	15	22	8	BL Weight + motor weight
B0	214	165	190		39	10	11	4	140	160	3	M8	8	33	30	35	5	17	15	22	15	
B1	263	194	230		61	12	11	6	170	200	4	M10	10	38	35	46	6	20.5	18	35	22	
B2	320	246	260		70	15	11	6	200	230	4	M10	14	48.5	45	61	6	24.5	22	40	43	
B3	390	294	340		80	20	13	6	270	310	5	M12	16	59	55	74	8	33	30	55	79	
B4	477	370	400		100	22	15	8	320	360	5	M12	20	74.5	70	92	10	38	35	62	127	
B5	564	438	490		115	30	18	12	400	450	5	M16	25	95	90	108	14	48.5	45	70	200	
B6	668	528	580		139	35	22	12	460	520	8	M20	28	106	100	130	14	53.5	50	80	400	
B7	775	578	650		182	40	22	12	520	590	10	M24	28	116	110	142	16	59	55	90	620	
B8	1061	814	880		210	50	38	12	680	800	10	M30	32	137	130	202	20	74.5	70	120	1220	
B9	1462	1151	1160		370	60	39	8	900	1020	10	M42	45	190	180	320	25	95	90	150	2500	
XL.XLD1-12																						
X1	197	147	160	Chart 11	48	9	12	4	110	134	3	M5	8	28	25	35	5	17	15	22	8.5	XL Weight + motor weight
X2	216	164	180		42	12	12	6	130	160	3	M8	8	28	25	34	6	17	15	22	15	
X3	263	194	230		51	15	12	6	170	200	4	M10	10	28	35	46	6	20.5	18	35	22	
X4	324	250	260		79	15	12	6	200	230	4	M10	14	48.5	45	63	6	24.5	22	40	43	
X5	401	305	340		93	20	13	6	270	310	4	M12	16	59	55	85	8	33	30	55	88	
X6	466	359	400		92	22	16	8	316	360	5	M12	18	69	65	80	10	38	35	62	130	
X7	484	377	430		114	22	18	8	345	390	5	M12	22	85	80	96	12	43	40	65	145	
X8	564	438	490		115	30	18	12	400	450	6	M16	25	95	90	110	14	48.5	45	70	195	
X9	691	551	580		170	35	22	12	455	520	8	M20	28	106	100	132	14	53.5	50	80	395	
X10	775	578	650		182	40	22	12	520	590	10	M24	28	116	110	142	16	59	55	90	620	
X11	1061	814	880		210	50	38	12	680	800	10	M30	32	137	130	202	20	74.5	70	120	1220	
X12	1462	1151	1160		370	60	39	8	900	1020	10	M42	45	190	180	320	25	95	90	150	2500	

GUOMAO REDUCER

Model BWE, BWED, XWE and XWED (Double reduction) Contour and Installation Dimensions

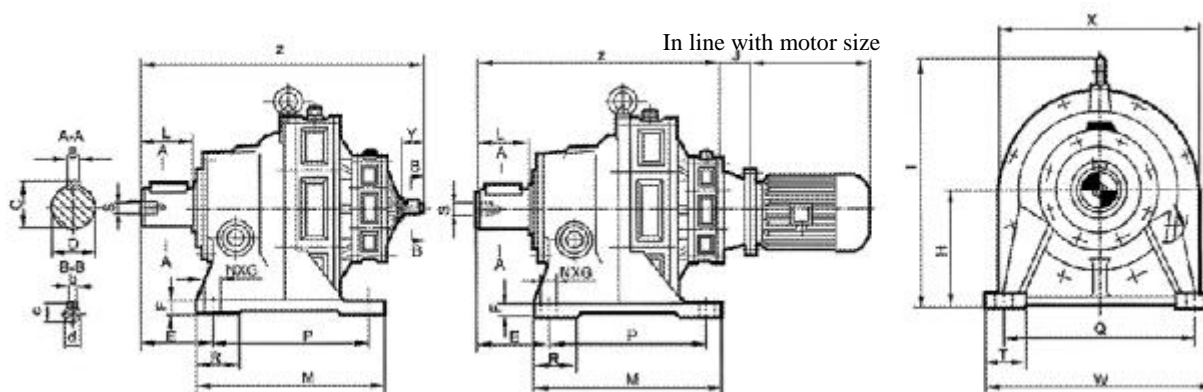

size	Contour Dimension						Installation Dimensions											Size of Shaft End						Weight(kg)			
	M	W	Z		I	X	J	H	E	F	P	Q	R	S	T	N	G	B	C	D	L	b	c	d	y	BWE	BWED About
BWE.BWED10-95																											
B10	160	280	317	267	250	200	120	124	15	110	240		M10	55	4	13	10	38	35	56	5	17	15	22	43		
B20	200	320	364	315	306	240	140	144	20	150	280		M10	60	4	13	14	48.5	45	71	5	17	15	22	50		
B31	250	390	446	376	356	300	160	159	25	200	340	65	M12	75	4	17	16	59	55	80	6	20.5	18	35	90		
B41	380	400	523	454	425	340	200	155	25	320	340	65	M12	80	4	22	20	74.5	70	102	6	20.5	18	35	140		
B42	380	400	554	479	425	340	200	155	25	320	340	100	M12	80	4	22	20	74.5	70	102	6	24.5	22	40	155		
B52	440	470	623	548	504	400	240	158	32	380	420		M16	80	4	22	25	95	90	120	6	24.5	22	40	240		
B53	440	470	657	561	504	400	240	158	32	380	420		M16	80	4	22	25	95	90	120	8	33	30	55	260		
B63	520	560	741	645	605	500	280	199	35	440	500		M20	90	4	26	28	106	100	139	8	33	30	55	460		
B74	600	690	832	725	706	575	325	230	40	500	630		M24	105	6	26	28	116	110	150	10	38	35	62	680		
B84	810	880	1071	962	880	700	420	324	50	660	800		M30	160	6	32	32	137	130	202	10	38	35	62	1320		
B85	810	880	1095	970	880	700	420	324	50	660	800		M30	160	6	32	32	137	130	202	14	48.5	45	70	1350		
B95	1040	1160	1502	1350	1160	1000	540	485	60	840	1050		M42	200	6	45	45	190	180	330	14	48.5	45	70	2750		
XWE.XWE42-12																											
X32	150	290	314	364	270	200	140	151	20	100	250		M10	55	4	16	16	38	35	56	5	17	15	22	40		
X42	195	330	370	315	316	240	150	169	22	145	290		M10	65	4	16	16	48.5	45	72	5	17	15	22	50		
X53	260	410	457	387	356	300	160	206	25	150	370		M12	75	4	16	16	59	55	91	6	20.5	18	35	110		
X63	335	430	510	441	425	340	200	125	30	275	380		M12	75	4	22	18	69	65	89	6	20.5	18	35	150		
X64	335	430	541	466	425	340	200	125	30	275	380		M12	75	4	22	18	69	65	89	6	24.5	22	40	160		
X74	380	470	561	486	484	340	220	145	30	320	420		M12	95	4	22	22	85	80	109	6	24.5	22	40	230		
X84	440	530	623	548	514	400	250	155	35	380	480		M16	120	4	22	25	95	90	120	6	24.5	22	40	260		
X85	440	530	682	586	514	400	250	155	35	380	480		M16	120	4	22	25	95	90	120	8	33	30	55	290		
X95	560	620	762	667	614	500	290	186	40	480	560		M20	120	4	26	28	106	100	141	8	33	30	55	470		
X106	600	690	832	725	706	575	325	230	40	500	630		M24	105	6	26	28	116	110	150	10	38	35	62	680		
X117	810	880	1071	962	880	700	420	324	50	660	800		M30	160	6	32	32	137	130	202	12	43	40	62	1320		
X118	810	880	1095	970	880	700	420	324	50	660	800		M30	160	6	32	32	137	130	202	14	48.5	45	70	1350		
X128	1040	1160	1445	1320	1160	1000	540	485	60	840	1050		M42	200	6	45	45	190	180	330	14	48.5	45	70	2750		

GUOMAO REDUCER

Model BLE, BLED, XLE and XLED (Double reduction) Contour and Installation Dimensions

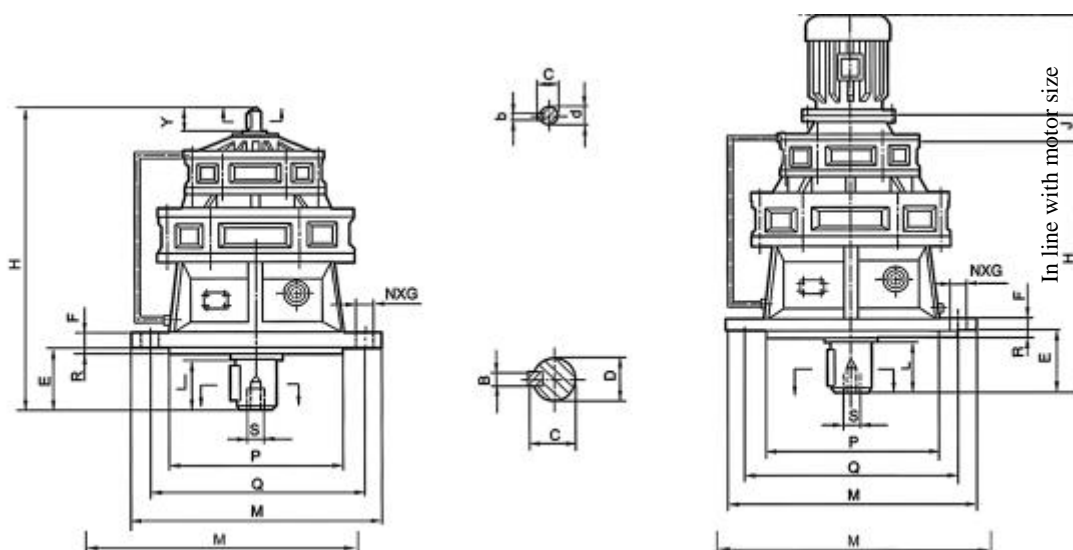

Size	Contour Dimension				Installation Dimensions								Size of Shaft End								Weight(kg)			
	H		M	J	E	F	G	N	P	Q	R	S	B	C	D	L	b	c	d	y	BLE	BLED About		
	BL	BLD																						
BLE.BLED10-95																								
B10	317	267	230	Chart 11	61	12	11	6	170	200	4	M10	10	38.5	35	49	5	17	15	22	38	BLE Weight + motor weight		
B20	368	318	260		70	15	11	6	200	230	4	M10	14	48.5	45	61	5	17	15	22	50			
B31	446	376	340		80	20	13	6	270	310	5	M12	16	59	55	74	6	20.5	18	35	95			
B41	521	454	400		100	22	15	8	320	360	5	M12	20	74.5	70	92	6	20.5	18	35	145			
B42	554	479	400		100	22	15	8	320	360	5	M12	20	74.5	70	92	6	24.5	22	40	160			
B52	623	548	490		115	30	18	12	400	450	5	M16	25	95	90	108	6	24.5	22	40	240			
B53	657	561	490		115	30	18	12	400	450	5	M16	25	95	90	108	8	33	30	55	260			
B63	741	645	580		139	35	22	12	460	520	8	M20	28	106	100	130	8	33	30	55	460			
B74	832	725	650		182	40	22	12	520	590	10	M24	28	116	110	142	10	38	35	62	690			
B84	1071	962	880		210	50	38	12	680	800	10	M30	32	137	130	202	10	38	35	62	1340			
B85	1095	970	880		210	50	38	12	680	800	10	M30	32	137	130	202	14	48.5	45	70	1370			
B95	1502	1350	1160	370	60	39	8	900	1020	10	M42	45	190	180	320	14	48.5	45	70	2750				
XLE.XLED42-128																								
X32	314	264	230	Chart 11	51	15	12	6	170	200	4	M10	10	38	35	46	5	17	15	22	38	XLE Weight + motor weight		
X42	370	320	260		79	20	12	6	200	230	4	M10	14	48.5	45	63	5	17	15	22	50			
X53	457	389	340		93	22	13	6	270	310	4	M12	16	59	55	85	6	20.5	18	35	110			
X63	510	441	400		92	22	16	8	316	360	5	M12	18	69	65	80	6	20.5	18	35	155			
X64	541	466	400		92	22	16	8	316	360	5	M12	18	69	65	80	6	24.5	22	40	170			
X74	561	486	430		114	22	18	8	345	390	5	M12	22	85	80	96	6	24.5	22	40	230			
X84	623	548	490		115	30	18	12	400	450	6	M16	25	95	90	110	6	24.5	22	40	260			
X85	658	588	490		115	30	18	12	400	450	6	M16	25	95	90	110	8	33	30	55	280			
X95	762	667	580		170	35	22	12	455	520	8	M20	28	106	100	132	8	33	30	55	480			
X106	832	725	650		182	40	22	12	520	590	10	M24	28	116	110	142	10	38	35	62	690			
X117	1108	983	880		210	50	38	12	680	800	10	M30	32	137	130	202	12	43	40	65	1340			
X118	1095	970	880	210	50	38	12	680	800	10	M30	32	137	130	202	14	48.5	45	70	1370				
X128	1445	1320	1160	370	60	39	8	900	1020	10	M42	45	190	180	320	14	48.5	45	70	2750				

GUOMAO REDUCER

Chart of size of connecting flange for assembling Y series motor

Motor connecting type

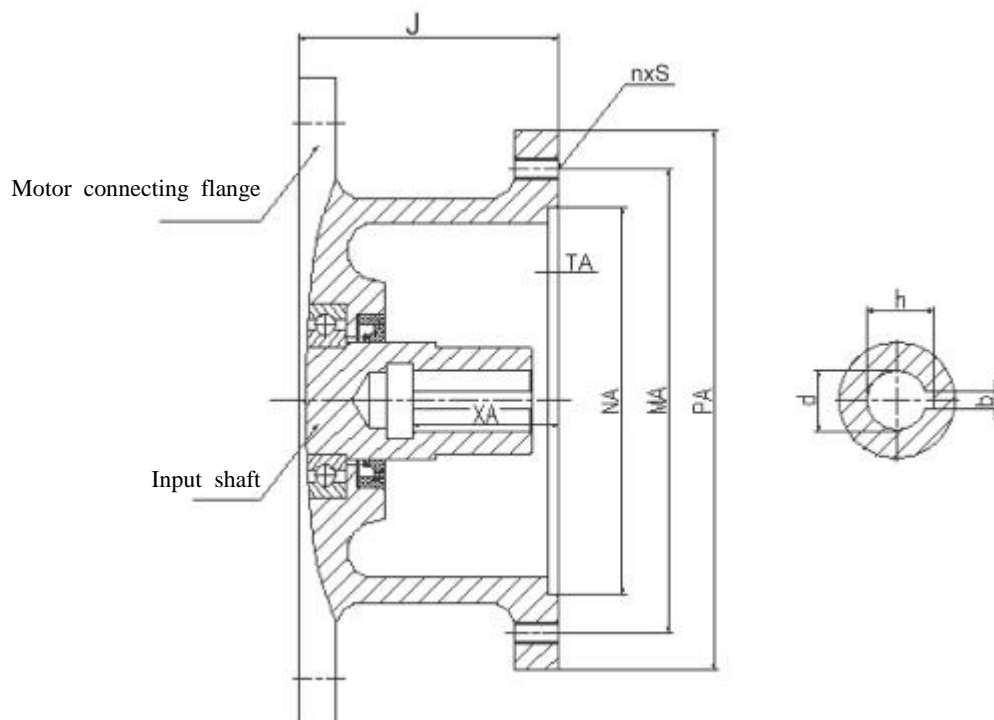

Chart 11

Model No.	Click			Size									
	Kw	Seat No.	No. of poles	NA	MA	PA	J	TA	n×S	XA	d	b	h
B09	0.18	Y63	4P	95	115	140	57.5	4	4×M8	23	11	4	12.8
	0.25、0.37	Y71		110	130	160	74.5	4	4×M8	30	14	5	16.3
	0.55	Y801		130	165	200	74.5	4	4×M10	40	19	6	21.8
B0 B10 B20	0.18	Y63		95	115	140	54.5	4	4×M8	23	11	4	12.8
	0.25、0.37	Y71		110	130	160	74.5	4	4×M8	30	14	5	16.3
	0.55、0.75	Y80		130	165	200	74.5	4	4×M10	40	19	6	21.8
	1.1	Y90S		130	165	200	83.5	4	4×M10	50	24	8	27.3
B1 B31 B41	0.25、0.37	Y71		110	130	160	83.5	4	4×M8	30	14	5	16.3
	0.55、0.75	Y80		130	165	200	83.5	4	4×M10	40	19	6	21.8
	1.1、1.5	Y90		130	165	200	83.5	4	4×M10	50	24	8	27.3
	2.2	Y100L1		180	215	250	90.5	4.5	4×M12	60	28	8	31.3
B2 B42 B52	0.55、0.75	Y80		130	165	200	93.5	5	4×M10	40	19	6	21.8
	1.1、1.5	Y90	130	165	200	93.5	5	4×M10	50	24	8	27.3	
	2.2、3	Y100	180	215	250	93.5	5	4×M12	60	28	8	31.3	
	4	Y112M	180	215	250	93.5	5	4×M12	60	28	8	31.3	

GUOMAO REDUCER

Chart of size of connecting flange for assembling Y series motor

Motor connecting type

Chart 11

Model No.	Click			Size									
	Kw	Seat No.	No. of poles	NA	MA	PA	J	TA	n×S	XA	d	b	h
B3 B53 B63	0.55、0.75	Y80	4P	130	165	200	118	5	4×M10	40	19	6	21.8
	1.1、1.5	Y90		130	165	200	118	5	4×M10	50	24	8	27.3
	2.2、3	Y100L		180	215	250	118	5	4×M12	60	28	8	31.3
	4	Y112M		180	215	250	118	5	4×M12	60	28	8	31.3
	5.5、7.5	Y132		230	265	300	118	5	4×M12	80	38	10	41.3
	11	Y160M		250	300	350	151	5	4×M16	110	42	12	45.3
B4 B74 B84	2.2、3	Y100L		180	215	250	125	5	4×M12	60	28	8	31.3
	4	Y112M		180	215	250	125	5	4×M12	60	28	8	31.3
	5.5、7.5	Y132		230	265	300	125	5	4×M12	80	38	10	41.3
	11	Y160M		250	300	350	151	5	4×M16	110	42	12	45.3
B5 B85 B95	2.2、3	Y100L		180	215	250	142	6	4×M12	60	28	8	31.3
	4	Y112M		180	215	250	142	6	4×M12	60	28	8	31.3
	5.5、7.5	Y132	230	265	300	142	6	4×M12	80	38	10	41.3	
	11、15	Y160M	250	300	350	142	6	4×M16	110	42	12	45.3	
	18.5	Y180M	250	300	350	142	6	4×M16	110	48	14	51.8	
B6	5.5、7.5	Y132	230	265	300	144	6	4×M12	80	38	10	41.3	
	11、15	Y160	250	300	350	144	6	4×M16	110	42	12	45.3	
	18.5、22	Y200L	6P	300	350	400	144	6	4×M16	110	55	16	59.3
B7	11、15	Y160	4P	250	300	350	129	7	4×M16	110	42	12	45.3
	18.5、22	Y200L	6P	300	350	400	129	7	4×M16	110	55	16	59.3
	30	Y225M		350	400	450	161	7	4×M16	140	60	18	64.4
	37	Y250M		450	500	550	161	7	4×M16	140	65	18	69.4
B8	18.5、22	Y200L		300	350	400	204	7	4×M16	110	55	16	59.3
	30	Y225M	350	400	450	234	7	4×M16	140	60	18	64.4	
	37	Y250M	450	500	550	234	7	4×M16	140	65	18	69.4	
	45、55	Y280	450	500	550	234	7	4×M16	140	75	20	79.9	
B9	30	Y225M	350	400	450	239	7	4×M16	140	60	18	64.4	
	37	Y250M	450	500	550	236	7	4×M16	140	65	18	69.4	
	45、55	Y280	450	500	550	236	7	4×M16	140	75	20	79.9	
	75	Y315S	550	600	660	236	7	4×M16	170	80	22	85.4	

Note: Changes may occur when other series of motors are assembled.

GUOMAO REDUCER

5. Maintenance (Disassembly and Assembly)

Our company manufactures all kinds of cycloidal reducers with same internal structure, whose disassembly and assembly basically have the same order. Lubrication oil should firstly be run out before disassembly, and oil pump of vertical reducer should be firstly disassembled. Order of disassembly is shown as Chart 4.

5.1. Disassembly: First loosen attachment bolt, and disassemble 4 and 10, and then successively disassemble parts of 6, 7 and 8. Assembly adopts the opposite order.

5.2. Assembly

Following attentions should be paid to assembly:

- 1) Clean all parts before assembly.
- 2) Lubricate rolling and sliding surface to form the condition of preliminary lubrication.
- 3) Tags of two cycloidal wheel must be kept 180°.
- 4) Carefully adjust the elasticity of spring in rubber oil seal and lubricate grease.
- 5) Inject lubricating oil or lubricating grease after assembly with horizontal oil level up to red line of oil pointer and vertical oil level up to middle line of oil pointer.
- 6) Manually turn high speed shaft, and make open drive if check is OK. Check the working condition of oil pump of vertical reducer, and put it into use if check is OK.
- 7) Strictly conform to requirements to disassemble direct-coupled motor, and it is forbidden to start disassembly from motor flange.

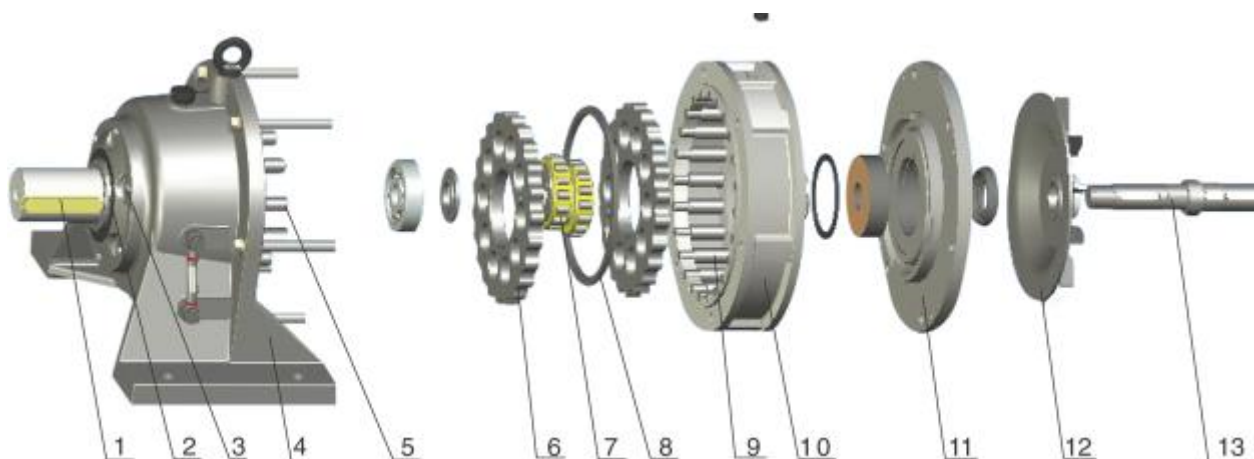

- | | | | |
|-------------------------|-------------------------------|----------------------|----------------|
| 1. output shaft | 2. tight ring of output shaft | 3. small end cap | 4. engine base |
| 5. pin bush of pin roll | 6. cycloidal wheel | 7. eccentric bearing | 8. spacer ring |
| 9. set of pin gear | 10. shell of pin gear | 11. big end cap | 12. fan cover |
| 13. input shaft | | | |



GUOMAO REDUCER

Chart of first-stage transmission oil seal

Model No.	Output end			Input end		
	Specification	Quantity		Double-shaft Specification	Motor connecting Specification	Motor direct-coupled Specification
		Horizontal type	Vertical type			
B09	30×52×10	1	1	20×35×10	30×60×10(0.18Kw) 35×60×12	15×35×10
B0	45×65×12	1	1	20×35×10	35×60×12 40×65×12(1.1kW)	15×35×10
B1	50×72×12	1	2	35×62×12	45×62×12	30×50×10
B2	65×90×12	1	2	40×65×12	50×72×12	40×65×12
B3	80×105×12	1	2	50×72×12	55×80×12 65×90×12(11kW)	40×65×12
B4	100×130×12	1	2	60×85×12	65×90×12	55×80×12
B5	115×140×14	1	2	80×105×12	80×105×12	70×95×12
B6	130×160×15	1	2	100×130×12	80×105×12	No-click direct-coupled type
B7	150×180×16	2	2	90×120×12	Please contact	
B8	170×200×18	2	2	130×160×15	130×160×15	
B9	220×260×18	2	2	160×190×16	140×170×15	

Chart of second-stage transmission oil seal

Model No.	Output end			Input end		
	Specification	Quantity		Double-shaft Specification	Motor connecting Specification	Motor direct-coupled Specification
		Horizontal type	Vertical type			
B10	50×72×12	1	2	35×62×12	35×60×12	15×35×10
B20	65×90×12	1	2	20×35×10	35×60×12 40×65×12 (1.1Kw)	15×35×10
B31	80×105×12	1	2	35×62×12	45×62×12	30×50×10
B41	100×130×12	1	2	35×62×12	45×62×12	30×50×10
B42	100×130×12	1	2	40×62×12	50×72×12	40×65×12
B52	115×140×14	1	2	40×65×12	50×72×12	40×65×12
B53	115×140×14	1	2	50×72×12	55×80×12 65×90×12 (11kW)	40×65×12
B63	130×160×15	1	2	50×72×12	55×80×12 65×90×12(11kW)	40×65×12
B74	150×180×16	2	2	60×85×12	65×90×12	55×80×12
B84	170×200×18	2	2	60×85×12	65×90×12	55×80×12
B85	170×200×18	2	2	80×105×12	80×105×12	70×95×12
B95	220×260×18	2	2	80×105×12	80×105×12	70×95×12

Note: 1 is selected without special indication.

GUOMAO REDUCER

Chart of first-stage drive bearing

Model No.	Output end		Input end				eccentric bearing (×2)		
	Bearing a	Bearing b	Double-shaft		Motor connecting			Motor direct-coupled	
			Bearing c	Bearing d	Bearing c	Bearing e			
B09	6205	6108	6201	6302		Bearing c	6205	Bearing c	502205
B0	6207	6207	6201	6302			6205		502205
B1	6208N	6208	6302	6304			6207		502206
B2	6211N	6213	6403	6404			6209		502307
B3	6213N	6215	6405	6406			6210		502309
							6212		
B4	6217N	6218	6406	6407			6212		502312
B5	6220N	6221	6407	6410			6215		502219
B6	23122	6224	6409	6413			6215		502222
B7	23124	6226	NJ410	6415	Please contact		No-click direct-coupled type		502228
B8	23128	6232	NJ414	6420	6322	502328			
B9	23136	6340	NJ417	6426	6324	502336			

Chart of second-stage drive bearing

Model No.	Output end		Input end				Mishap shaft bearing		Eccentric bearing (X2)				
	Bearing a	Bearing b	Double-shaft		Motor connecting		Motor direct-coupled		Low speed end	High speed end			
			Bearing c	Bearing d	Bearing c	Bearing e	Bearing c	Bearing f			Bearing g		
B10	6208N	6208	6201	6302		Bearing c		6205	Bearing c	6302	6207	502206	502205
B20	6211N	6213	6201	6302				6205		6403	6207	202307	502205
B31	6213N	6215	6302	6304				6207		6405	6208	502309	502206
B41	6217N	6218	6302	6304				6207		6406	6208	502312	502206
B42	6217N	6218	6403	6404				6209		6406	6212	502312	502307
B52	6220N	6221	6403	6404				6209		6407	6213	502219	502307
B53	6220N	6221	6405	6406				6210		6407	6215	502219	502309
B63	23122	6224	6405	6406				6210		6409	6215	502222	502309
B74	23124	6226	6406	6407				6212		NJ410	6218	502228	502312
B84	23128	6232	6406	6407	6212		NJ414	6218		502328	502312		
B85	23128	6232	6407	6410	6215	NJ414	6218	502328	502219				
B95	23136	6340	6407	6410	6215	NJ417	6222	502336	502219				

Note: 1 is selected without special indication.

II Series of Special Cycloidal Pinwheel reducer

In line with requirements of all trades, our company has designed various reducers for special purposes, whose internal parameters are same to those of cycloidal pin wheel reducers with same specifications, whose performance and index comply with requirements of JB/T13324- L997. Manufacturers of all trades are welcome to seek cooperation, and we will provide you with all kinds of designs and manufacture of non-standard products.

1. BJ series of reducers

BJ series of reducers are specially designed as supporting equipment of plastic extruder, with small volume and simple structure, convenient for maintenance, replacing old-fashioned gear box. 。 performance parameters are as follows:

Model type	Input speed rpm	Allowable torque N.m	Transmission ratio i	Input power KW
BJ3	1500	1000	11,17,23	7.5,5.5
BJ5	1500	3000	11,17,23	18.5,15
BJ35	1500	4200	14.5	22

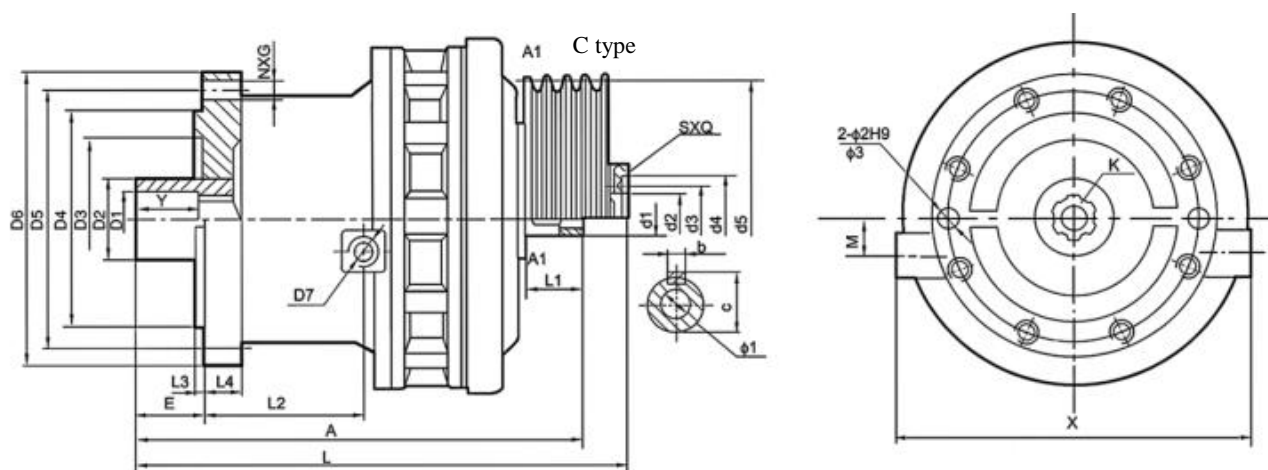

Model No.	D1	D2	D3	D4	D5	D6	L1	L2	L3	L4	E	A	L	X	N	G	μ1	μ2	
BJ3	60	75	160	200	236	280	75	128	8	38	62	395		305	10	M16	18	16	
BJ5	80	100	210	280	330	380	81	209	9	45	82	535		410	8	M22	28	20	
BJ35	80	100	210	280	330	380		209	9	45	82		635	450	8	M22	28	20	
Model No.	S	Q	M	b	c	d1	d2	d3	d4	d5	Y	μ3	d7	K					
BJ3			45	8	33	30hb					64	250	M24				6-38×33×10		
BJ5			45	14	48.5	45hb					76	330	M30				6-55×50×14		
BJ35	4	M6	45				62	75	98	348	76	330	M30				6-55×50×14		

Note: BJ3, -Ø2 turns clockwise18°

GUOMAO REDUCER

2. BJS series of reducers

BJS series of reducers are designed and manufactured to support rebar thread machine for construction users, whose performance index accords with usage requirement of trade, with specifications of BJSA3 and BJSC3.

Contour and installation size of BJSA3 reducer

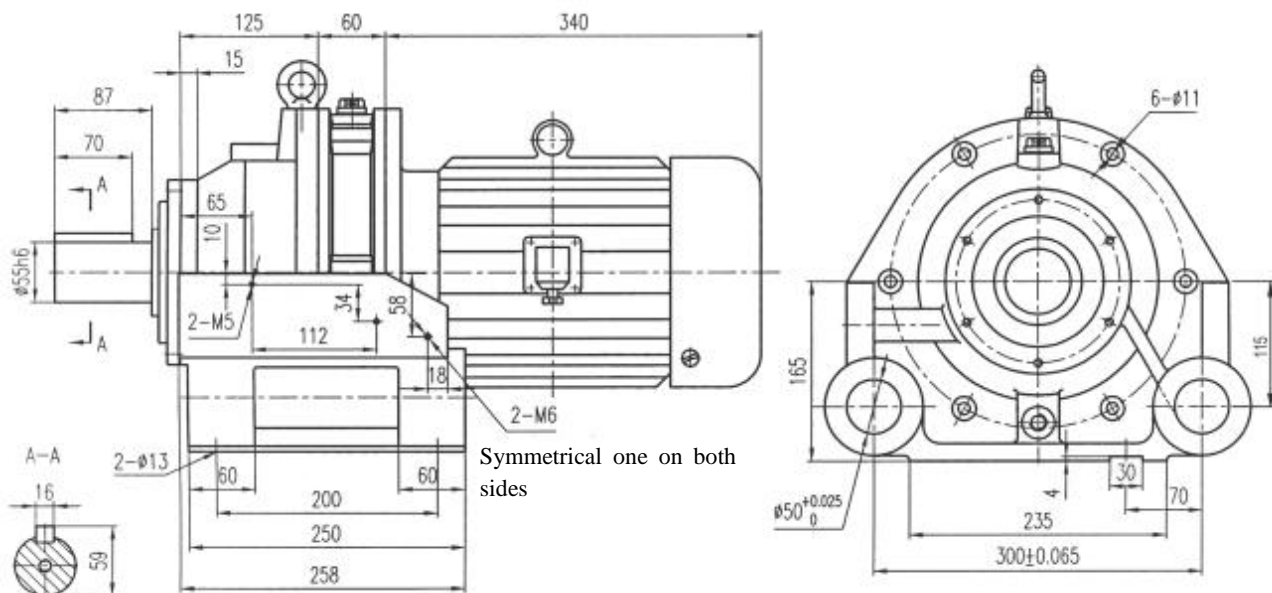

Contour and installation size of BJSC3 reducer

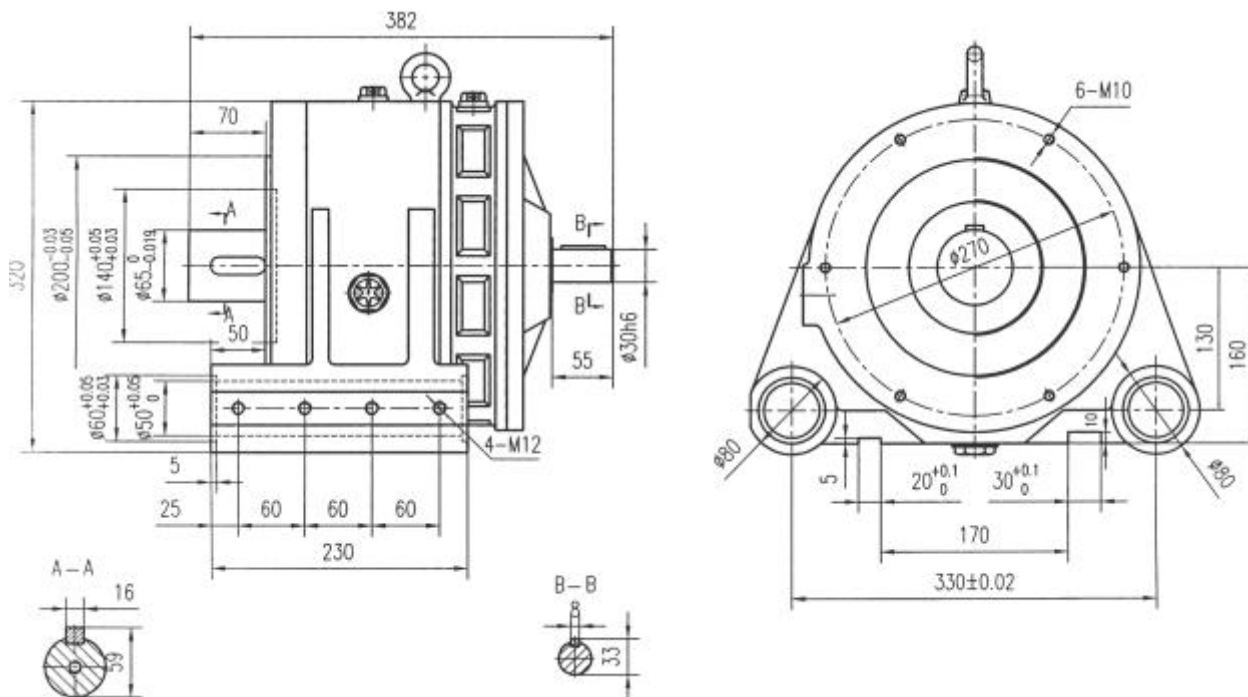

III Notice for Use and Lubrication

3.1 Use

3.1.1 Reducers are applicable to system of 24-hour continuous duty and allowed to run forward and reverse.

3.1.2 Output shaft and input shaft of single reduction reducers have opposite steering while output shaft and input shaft of double reduction reducers have identical steering.

3.1.3 Reducers have no self-locking.

3.1.4 Output shaft of reducer can't bear axial force.

3.1.5 Overload protection equipment should be installed on occasions that overload phenomenon may occur.

3.1.6 Foot-styled horizontal cycloidal pinwheel reducer should be installed on non-vibrating solid horizontal base. When tilt installation is necessary, inclination of shaft axis of reducer should be in the scope of $\pm 15^\circ$.

3.1.7 When cycloidal pinwheel reducer with vertical flange is installed, output shaft should be positioned straight down.

3.1.8 If it needs other special installation types except foot-styled horizontal and vertical flange forms, corresponding lubricating and sealing measures must be taken to ensure sufficient lubrication of reducer and prevent oil leak. Please contact with our technical department.

3.1.9 After lubricated with grease, cycloidal pinwheel reducer can take free angle of installation.

3.1.10 When reducer is installed, no more than three cushion blocks can be used for adjustment in the direction of height. Drift can also be used for adjustment, but must be replaced by flat cushion blocks after reducer is calibrated.

3.1.11 When there are big impact and vibration or frequent starts on use occasions, engine seating and base should be connected with anchor bolt and fastened with locating pin (self-prepared).

3.1.12 Cylindrical is the form of shaft extension of input shaft and output shaft in standard cycloidal pinwheel reducers, which adopt general flat key connection, with h6 size tolerance of shaft diameter. Size of general flat key is in accordance with the stipulation of GB1096—79 *Size of General Flat Key*. Seam allowance of connecting flange is In accordance with h9 of GB1801-79.

3.1.13 Elastic coupling is recommended when coupling is adopted to connect cycloidal pinwheel reducer with supporting machinery.

3.1.14 when coupling is adopted to connect cycloidal pinwheel reducer with supporting machinery, axially of two shaft axis should not exceed the allowable scope of coupling.

3.1.15 When cycloidal pinwheel reducer connects with wheel gear and chain wheel, parallelism of two shaft axis must be ensured.

3.1.16 When chain wheel is used for transmission, wheel gear should not be loosened. Otherwise, impact may occur at the start.

3.1.17 When coupling or wheel gear is connected with output shaft of cycloidal pinwheel reducers, direct hammering must be avoided.

3.1.18 After installation, test run must be operated before reducer is put into use. Under the condition of normal no-load running, load running can be gradually started.

GUOMAO REDUCER

3.2 Lubrication

3.2.1 Methods of lubrication:

Table of lubrication methods of cycloidal pinwheel reducers in form of standard installation:

methods of lubrication									lubricating oil		
Single reduction			double reduction			three-stage reduction			Ambient temperature	EP gear oil	ISO EP gear oil
model	horizontal installation	Vertical installation	model	horizontal installation	Vertical installation	model	horizontal installation	vertical installation	-5~10	L-CKC100	EP68
B09~2	grease		B10~20	grease		B310	grease		0~35	L-CKC100 L-CKC150	EP150
B3~9	oil bath type	lubricant pump	B31~95	oil bath type	lubricant pump	B420 ~ 953	oil bath type	lubricant pump	30~50	L-CKC220 L-CKC320 L-CKC460	EP220~460

Note: When grease is adopted to lubricate reducers, 2# lithium grease, 2#extreme pressure lithium grease or 00# reducer grease is recommended.

3.2.2 Lubricating oil must be injected into reducer before its use, and reducers often don't contain lubricating oil for convenience of assembly, disassembly and transportation at time of shipping out of factory.

3.2.3 Lubricating grease has been injected into reducers that need grease lubrication before shipping out of factory.

3.2.4 Lubricating oil should be reconsidered when cycloidal pinwheel reducers work under bad working condition, on high-temperature or low-temperature occasions, or suffer from frequent start-stops.

3.2.5 When lubricating oil is injected, oil level should not exceed up limit of oil pointer or be under the lower limit of oil pointer. During the process of running, attention should often be paid to oil level, and lubricating oil with identical brand should be replenished.

Oil and grease content of cycloidal pinwheel reducer in forms of standard installation:

Model No.(horizontal and vertical)		B09	B0	B1	B2	B10	B20			
Infusing volume of lubricating grease(kg)		0.14	0.16	0.37	0.75	0.43	0.85			
Model No.		B3	B4	B5	B6	B7	B8	B9	B31	B41
Infusing volume of lubricating oil(L)	Horizontal	1.4	2.2	4.5	7	14	30	56	1.5	2.2
	Vertical	2.5	3.8	6	11	14	30	60	3	4
Model No.		B42	B52	B53	B63	B74	B84	B85	B95	
Infusing volume of lubricating oil(L)	Horizontal	3.3	6	6.3	10	16	35	36	70	
	Vertical	4	6	6.5	11	16	35	36	70	

3.2.6 System of renewing lubricating oil:

After reducer runs for 300 hours for the first time, first renewal of lubricating oil should be made and remaining sump oil should be removed. Afterwards, if reducer works for more than successive 10 hours, renewal of lubricating oil should be made every 3 months; otherwise, renewal should be made every 6 months.

3.2.7 System of renewing grease: Once every 6 months.

3.2.8 Lubricating oil or grease must be renewed before start if reducer has not been operated for a long time.

3.2.9 Unclean or corrosive lubricating oil is forbidden to be injected.

IV Rack of Chemical Retort

4.1 HG5-251-79

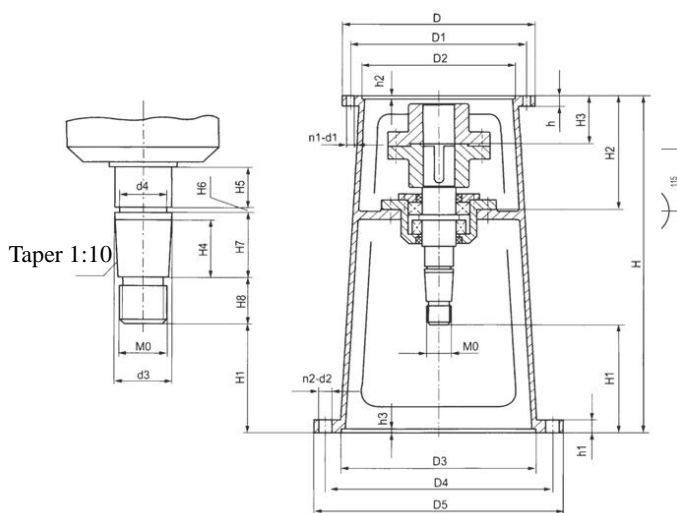

Rack model	Reducer model	Input interface						Output interface						Size		
		D	D1	D2	h	H2	n1-d1	D3	D4	D5	h3	h1	n2-d2	H	H1	H2
JBT ₁	B1	230	200	170	18	5	6-12	220	270	305	7	20	4-24	514	157	175
JBT ₂	B1	230	200	170	18	5	6-12	250	300	335	7	20	4-24	517	150	175
JBT ₂	B2	260	230	200	18	5	6-12	250	300	335	7	20	4-24	530	134	209
JBT ₃	B2	260	230	200	20	5	6-12	295	350	392	7	23	4-24	560	164	209
JBT ₃	B3	340	310	270	20	6	6-13.5	295	350	392	7	23	4-24	560	165	210
JBT ₄	B3	340	310	270	20	6	6-13.5	345	400	442	7	24	4-24	635	203	215
JBT ₅	B3	340	310	270	22	6	6-13.5	390	450	498	7	25	4-30	680	193	239
JBT ₅	B4	400	360	316 320	22	6	8-16	390	450	498	7	25	4-30	680	193	239
JBT ₆	B4	400	360	316 320	22	6	8-16	435	500	548	7	26	8-30	736	215	253
JBT ₇	B5	490	450	400	26	7	12-18	440	550	600	10	28	12-22	805	180	296
JBT ₈	B6	580	520	455 460	30	10	12-22	500	550	600	10	30	12-22	820	170	358
JBT ₉	B7	650	590	520	30	12	12-22	560	650	700	10	35	16-27	1100	326	455
JBT ₁₀	B8	880	800	680	38	12	12-37	720	810	880	10	40	20-27	1200	409	460

Rack model	Reducer model	Volume of retort(liter)	Size										
			H3	H4	H5	H6	H7	H8	d3	d4	M0		
JBT ₁	B1	50-100	77	33	52	4	39	34	30	24	M24×3		
JBT ₂	B1	200	77	44	52	5	50	32	39	32	M33×3.5		
JBT ₂	B2	200	93	44	43	5	50	32	39	32	M33×3.5		
JBT ₃	B2	300-500	93	47	38	5	53	34	39	32	M33×3.5		
JBT ₃	B3	300-500	92	47	36	5	53	34	39	32	M33×3.5		
JBT ₄	B3	1000-2000	92	53	43	5	61	44	50	41.5	M42×4.5		
JBT ₅	B3	3000	92	58	68	5	66	45	60	51.5	M52×5		
JBT ₅	B4	3000	119	58	68	5	66	45	60	51.5	M52×5		
JBT ₆ /JBT ₆ -B	B4	5000	117	58	67	9	66	50 45	70 60	61.5 51.5	M64×6 M52×5		
JBT ₇ /JBT ₇ -B	B5		140	80	94	8	88	50	90	79	M80×6 M80×2		
JBT ₈ /JBT ₈ -B	B6		183	90	44	9	98	50	100	89	M90×6 M90×2		
JBT ₉ /JBT ₉ -B	B7		204	100	50	10	110	50	110	99	M98×6 M98×2		
JBT ₁₀ /JBT ₁₀ -B	B8		219	100	50	10	110	50	130	119	M118×6 M118×2		

Note: Five kinds of racks, JBT6, JBT7, JBT8, JBT9 and JBT10, have thread M0 with two respective specifications, and you'd better give clear indication of ordering. Without clear indication, we will deliver standard racks without note -B.

GUOMAO REDUCER

Model	Size of shaft end of mixer shaft																				DJ type		LDJ type	
	h(A/B)	H0	h1	h2	h3	h4	h5	h6	d0	d1	d2	M1	d3(h9)	zd4	b	b1	b2	t	t1	T2	H	Weight	H	Weight
DJ,LDJ30 ^A / _B	250/254	53	103	3	13	22	30	3	30	32	32.8	M35×1.5	35	40	8	6	6	26	31	31.5	550	46(kg)	700	54(kg)
DJ,LDJ35A	253	53	113	3	15	24	40	3	35	42	42.8	M45×1.5	45	50	10	6	6	30	41	41.5	600	79	750	89
DJ,LDJ40 ^A / _B	242/249	69	113	3	15	24	40	3	40	42	42.8	M45×1.5	45	50	12	6	6	35	41	41.5	600	79	750	89
DJ,LDJ45A	246	69	113	3	15	28	40	3	45	47	47.8	M50×1.5	50	65	14	8	8	39.5	46	46	600	84	750	94
DJ,LDJ55 ^A / _B	274/272	80	118	4	15	27	40	3	55	57	57	M60×2	60	65	16	8	8	49	56	56	660	151	760	157
DJ,LDJ65A	333	87	143	4	18	32	50	3	65	71	72	M75×2	75	80	18	10	10	58	69	70	720	171	870	181
DJ,LDJ70 ^A / _B	333/327	87	143	4	18	32	50	3	70	71	72	M75×2	75	80	20	10	10	62.5	69	70	720	171	870	181
DJ,LDJ80 ^A / _B	371/340	91	163	4	18	32	60	3	80	81	82	M85×2	85	90	22	10	10	71	79	80	785	209	935	219
DJ,LDJ90A	375	125	168	4	20	36	60	3	90	91	92	M95×2	95	110	25	12	12	81	89	90	805	266	955	276
DJ,LDJ100 ^A / _B	386/360	134	178	4	24	42	60	3	100	111	112	M115×2	115	125	28	14	14	90	109	109.5	820	347	1020	362
DJ,LDJ110	456	155	178	4	24	42	60	3	110	112	112	M115×2	115	125	28	14	14	100	109	109.5	1100	533	1150	537
DJ,LDJ120A	456	155	178	4	24	42	60	3	120	122	122	M125×2	125	140	32	14	14	109	119	119.5	1100	553	1150	557
DJ,LDJ130 ^A / _B	570/570	197	208	4	28	46	70	3	130	135	137	M140×2	140	150	32	14	14	119	132	134.5	1200	723	1400	754
DJ,LDJ140A	570	197	208	4	28	48	70	3	140	145	147	M150×2	150	160	36	16	16	128	142	144	1200	743	1400	774
DJ,LDJ150	Up to reducer model no.	210	208	4	32	52	70	3	150	155	156	M160×3	160	170	36	16	16	138	152	154	1200	765	1400	798
DJ,LDJ160		210	227	4	32	52	80	3	160	165	166	M170×3	170	180	40	16	16	147	162	164	1200	780	1400	820
DJ,LDJ180		235	242	4	36	58	90	3	180	185	186	M190×3	190	200	45	18	18	165	180	182	1280	887	1400	933

Note: "h" in the Chart only matches sample BLD series of reducers. If other models or reducers manufactured by other factories are selected, "h" needs separate calculation. The underpart space of the heightened LDJ model rack can contain double-end mechanical seal of 205, 206 or 207.

4.3 New phenotype racks of JXLD and JBLD

4.3.1 JXLD Rack (74 standard)

The rack can directly couple 10 kinds of models under XLD reducers demonstration of model calibration:

JXLD X XX X

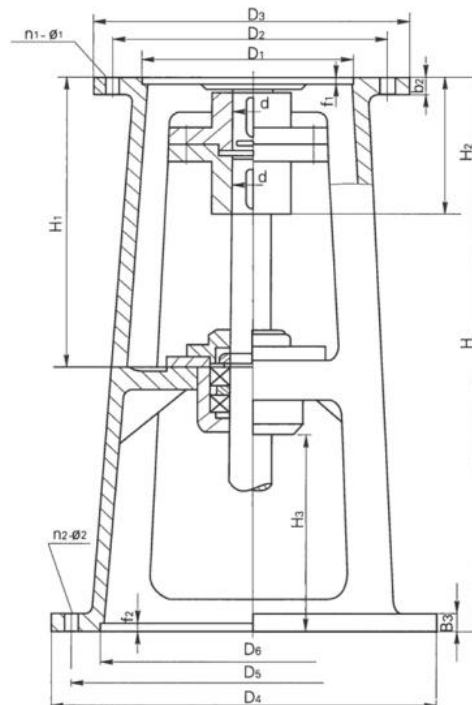
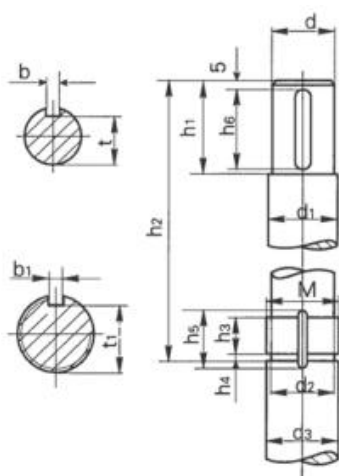
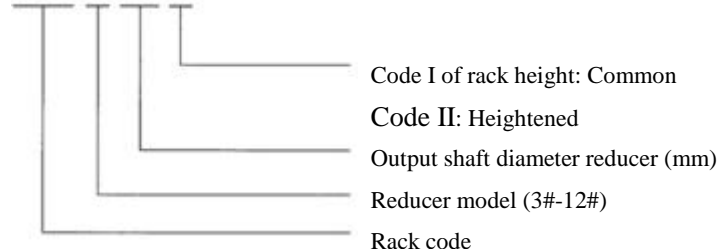

Chart 5-14 JXLD rack



GUOMAO REDUCER

Major parameters and size of JXLD racks

Rack code	Output shaft diameter d of reducer	Shaft end size of mixer shaft														Contour and connecting size											I-typed		II-typed				
		d1	M	d2	d3 (K6)	h1	h2	h3	h4	h5	h6	b	b1	t	t1	H1	H2	D3	D2	D1	n ₁ -i _Q	D4	D5	D6 (H9)	t2	b2	N ₂ -i _Q	H	H3	Weight (kg)	H	H3	Weight (kg)
JXLD3	35	40	M45×1.5	42.8	45	60	215	10	3	16	50	10	6	30	41	291	136	230	200	170	6-12	410	360	300	6	18	6-18	520	170	55	610	260	80
JXLD4	45	50	M55×2	52	55	75	235	14	4	22	69	14	8	39.5	51	335	175	260	230	200	6-12	450	400	335	6	18	6-18	570	155	80	670	255	86
JXLD5	55	60	M65×2	62	65	75	301	14	4	22	70	16	8	49	61	404	178	340	310	270	6-13	500	450	385	6	22	8-18	650	157	110	750	257	120
JXLD6	65	70	M75×2	72	75	90	316	16	4	25	85	18	10	58	70	402	215	400	360	316	8-16	530	480	410	8	22	12-18	660	168	130	760	268	145
JXLD7	80	85	M90×2	87	90	105	316	20	4	30	100	22	12	71	84	441	230	430	390	345	8-18	565	510	430	8	24	12-22	740	194	160	860	314	178
JXLD8	90	95	M100×2	97	100	125	320	20	4	30	120	25	12	81	94	471	276	490	450	400	12-18	565	510	430	8	28	12-22	800	212	208	920	332	230
JXLD9	100	105	M110×2	107	110	125	308	20	4	31	120	28	14	90	104	496	313	580	520	455	12-22	580	520	455	10	30	12-22	810	191	235	920	301	262
JXLD10	110	115	M120×2	117	120	155	267	24	4	35	150	28	14	100	114	475	363	650	590	520	12-22	650	590	520	12	30	12-22	830	221	300	950	341	345
JXLD11	130	135	M140×2	137	140	155	301	28	4	39	150	32	14	119	132	521	880	880	800	680	12-38	880	800	680	12	30	12-37	850	185	480	970	305	538
JXLD12	180	190	M200×3	196	200	284	377	36	4	48	280	45	16	165	190	757	1160	1160	1020	900	8-39	1160	1020	900	12	45	8-39	1200	235		350	385	

Note: “h₂” in the Chart only matches sample XLD series of reducers. If other models or reducers manufactured by other factories are selected, “h” needs separate calculation. I model is common and II model is heightened. Except enlarged size of H and H₃, other sizes are the same to that of I model.

GUOMAO REDUCER

4.4 DXJ Rack

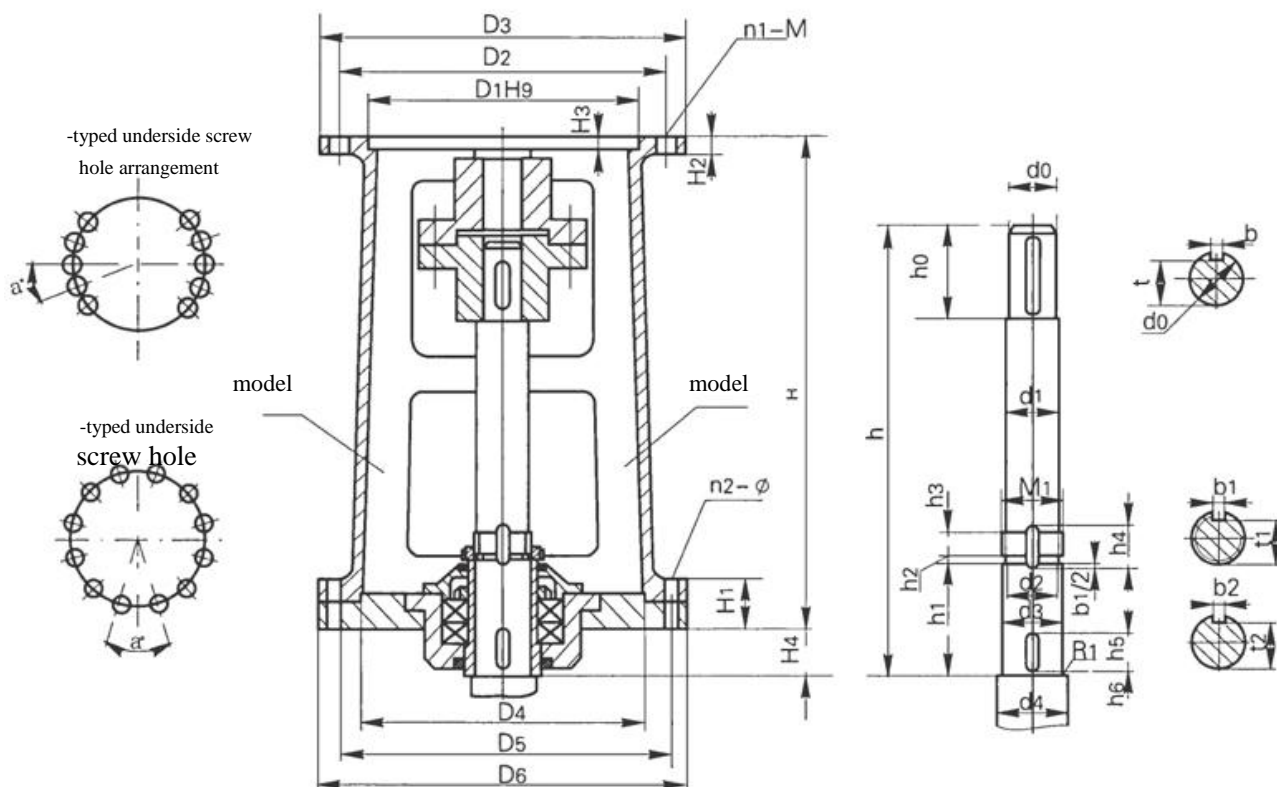

Chart 5-12 DXJ model rack

Model	H	H1	H2	H3	H4	Input interface				Output interface				
						D_1	D_2	D_3	$n1-M$	D_4	D_5	D_6	\dot{A}	$n2-\mu$
DJ,LDJ30 ^A _B	470	40	15	4	45	140 200	160 230	190 260	4-M10 6-M12	240	285	315	I20 II30	10- μ 14 12- μ 14
DJ,LDJ35A	524	48	15	5	47	170	200	230	6-M10 6-M12	260	320	360	I20 II30	10- μ 14 12- μ 14
DJ,LDJ40 ^A _B	524	48	15	4	47	200 230	230 260	260 290	6-M10 6-M12	260	320	360	I20 II30	10- μ 14 12- μ 14
DJ,LDJ45A	524	48	15	5	49	200	230	260	6-M10 6-M12	260	320	360	I20 II30	10- μ 14 12- μ 14
DJ,LDJ55 ^A _B	570	60	20	6 5	47	270	310 305	340	6-M10 8-M16	325	400	435	30	12- μ 14
DJ,LDJ65A	634	68	20	6 5	58	316	360	400	8-M12 8-M16	350	420	460	30	12- μ 18
DJ,LDJ70 ^A _B	634	68	20	6	58	316(320) 320	360	400	8-M12 8-M16	350	420	460	30	12- μ 18
DJ,LDJ80 ^A _B	678	76	25	6 5	70	345 360	390 410	430 460	8-M16 8-M20	380	455	495	30	12- μ 18
DJ,LDJ90A	700	80	25	7	72	400	450	490	12-M16 12-M20	430	510	555	30	12- μ 23
DJ,LDJ100 ^A _B	740	80	25	9 5	76	455(460) 470	520	580	12-M20	480	560	600	22.5	16- μ 23
DJ,LDJ110A	840	80	30	11 6	76	520	590	650	12-M20	560	650	700	22.5	16- μ 27
DJ,LDJ120A	840	80	30	11 6	76	520	590	650	12-M20	560	650	700	22.5	16- μ 27
DJ,LDJ130 ^A _B	950	94	30	11 9	85	680	800	880	12-M30	720	810	880	18	20- μ 27
DJ,LDJ140A	950	94	30	11 9	85	680	800	880	12-M30	720	810	880	18	20- μ 27
DJ,LDJ150 ^A _B	950	94	35	14 10	85	820	940	1020	16-M30	840	940	1020	22.5	16- μ 33
DJ,LDJ160 ^A _B	950	100	35	14 10	95	820	940	1020	16-M30	840	940	1020	22.5	16- μ 33
DJ,LDJ180 ^A _B	1050	100	40	14 10	115	960	1080	1160	20-M30	970	1080	1160	18	20- μ 33

GUOMAO REDUCER

Model	Shaft end size of mixer shaft																				Weight (kg)
	h(A/B)	h0	h1	h2	h3	h4	h5	h6	d0	d1	d2	M1	d3(h9)	d4	b	t	t1	b1	t2	b2	
DJ,LDJ30 ^{A/B}	431/445	53	103	3	13	22	30	3	30	32	32.8	M35×1.5	35	40	8	26	31	6	31.5	48	48
DJ,LDJ35A	490	53	113	3	15	24	40	3	35	42	42.8	M45×1.5	45	50	10	30	41	6	41.5	62	62
DJ,LDJ40 ^{A/B}	479/482	69	113	3	15	24	40	3	40	42	42.8	M45×1.5	45	50	12	35	41	6	41.5	62	62
DJ,LDJ45A	481	69	113	3	15	28	40	3	45	47	47.8	M50×1.5	50	65	14	39.5	46	8	46	67	67
DJ,LDJ55 ^{A/B}	530	80	118	4	15	27	40	3	55	57	57	M60×2	60	65	16	49	56	8	56	107	107
DJ,LDJ65A	590	87	143	4	18	32	50	3	65	71	72	M75×2	75	80	18	58	69	10	70	150	150
DJ,LDJ70 ^{A/B}	590/580	8791	143	4	18	32	50	3	70	71	72	M75×2	75	80	20	62.5	69	10	70	150	150
DJ,LDJ80 ^{A/B}	630/590		163	4	18	32	60	3	80	81	82	M85×2	85	90	22	71	79	10	80	213	213
DJ,LDJ90A	636	125	168	4	20	36	60	3	90	91	92	M95×2	95	110	25	81	89	12	90	12	276
DJ,LDJ100 ^{A/B}	667/641	134	178	4	24	42	60	3	100	111	112	M115×2	115	125	28	90	109	14	109.5	14	326
DJ,LDJ110A	712	155	178	4	24	42	60	3	110	112	112	M115×2	115	125	28	100	109	14	109.5	14	505
DJ,LDJ120A	712	155	178	4	24	42	60	3	120	122	122	M125×2	125	140	32	109	119	14	119.5	14	510
DJ,LDJ130 ^{A/B}	815/815	197	208	4	28	46	70	3	130	135	137	M140×2	140	150	32	119	132	14	134.5	14	689
DJ,LDJ140A	815	197	208	4	32	52	70	3	140	145	147	M150×2	150	160	36	128	142	16	144	16	696
DJ,LDJ150 ^{A/B}	Up to reducer model no.	210	208	4	32	52	70	3	150	155	156	M160×3	160	170	36	138	152	16	154	16	708
DJ,LDJ160 ^{A/B}		210	227	4	32	52	80	3	160	165	166	M170×3	170	180	40	147	162	16	164	16	930
DJ,LDJ180 ^{A/B}		290	242	4	36	52	90	3	180	185	189	M190×3	190	2000	45	165	180	18	182	18	1240

Note: “h” in the Chart only matches sample BLD series of reducers. If other models or reducers manufactured by other factories are selected, “h” needs separate calculation.

GUOMAO REDUCER

4.5 SJ and LSJ Rack

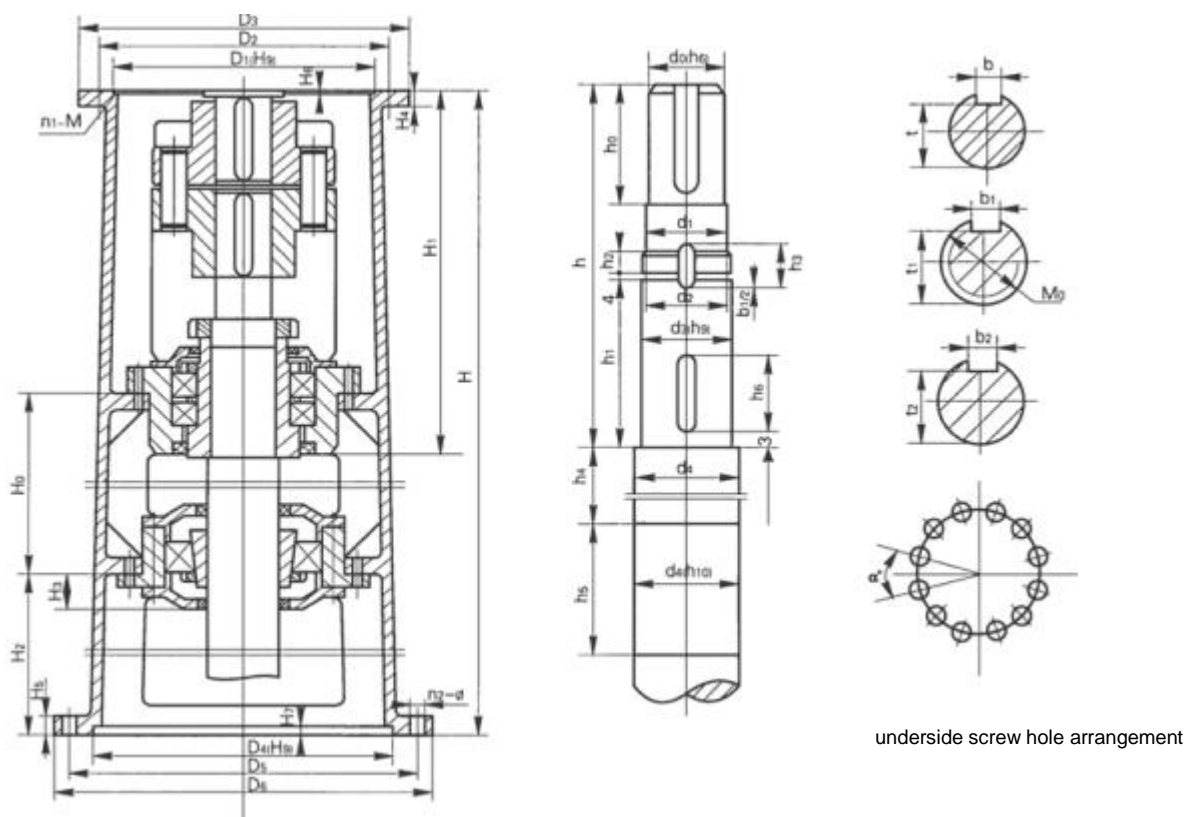

Chart 5-13 SJ and LSJ

Major parameters and size of SJ and LSJ double-fulcrum racks

Rack code	H0	H1	H3	H4	H5	H6	H7	D ₁	D ₂	D ₃	n1-M	D ₄	D ₅	D ₆	∠Á	n2-∣μ
SJ,LSJ55 ^A _B	450	402	58	22	24	6	6	270	310 305	340	6-M10 8-M16	325	400	435	30	12-∣μ14
SJ,LSJ65 ^A _B	450	487	58	22	24	6 5	6	316	360	400	8-M12 (8-M16)	350	420	460	30	12-∣μ18
SJ,LSJ70 ^A _B	450	487	58	22	24	6 5	6	316(320) 320	360	400	8-M12 8-M16	350	420	460	30	12-∣μ18
SJ,LSJ80 ^A _B	450	545	60	25	28	6 5	8	345 360	390 410	430 460	8-M16 8-M20	380	455	495	30	12-∣μ23
SJ,LSJ90A	600	569	69	25	40	7	8	400	450	490	12-M16 (12-M20)	430	510	555	30	12-∣μ23
SJ,LSJ100 ^A _B	600	685	61	30	40	9 5	10	455(460) 470	520	580	12-M20	480	560	600	22.5	16-∣μ23
SJ,LSJ110A	600	685	61	38	40	11	10	520	590	650	12-M20	560	650	700	22.5	16-∣μ27
SJ,LSJ120A	600	685	61	38	40	11	10	520	590	650	12-M20	560	650	700	22.5	16-∣μ27
SJ,LSJ130 ^A _B	650	761	85	40	45	11 9	10	680	800	880	12-M30	720	810	880	18	20-∣μ27
SJ,LSJ140A	650	761	85	40	45	11 9	12	680	800	880	12-M30	720	810	880	18	20-∣μ27
SJ,LSJ150 ^A _B	650	761	76	50	50	14 10	12	820	940	1020	16-M30	840	940	1020	22.5	16-∣μ33
SJ,LSJ160 ^A _B	650	780	81	50	50	14 10	12	820	940	1020	16-M30	840	940	1020	22.5	16-∣μ33
SJ,LSJ180 ^A _B	650	910	83	50	50	14 10	12	960	1080	1160	20-M30	970	1080	1160	18	20-∣μ33